



2101 **Ball Joint Separator Set (5pcs)**
多功能球頭拔卸組 (5pcs)

- * Innovative quick change and simple action for suitable fork.
- * Enable operator to select correct jaw size without taking entire extractor to the vehicle.
- * Adjustable opening angle.
- * Fork opening: 20, 22, 24, 27, 30mm
- * Thrust screw: 100mm(L)
- * Pivot rod: 125mm(L)



2102 **2-Way Hydraulic Ball Joint Separator Set**
多功能球頭拔卸組 (油壓式)

- * Specially designed to be operated manually or by 12 tonne hydraulic ram.
- * Features a step down tread adaptor that allows fitting of the manual thrust screw or 12 tonne hydraulic ram supplied.
- * For splitting track-rod ends, anti-roll bar mounting and ball joint.
- * Fork opening: 30, 34, 40mm
- * Thrust screw: 100, 80mm(L)
- * Pivot rod: 125mm(L)



2103 **Ball Joint Separator Set (3pcs)**
立式球頭拔卸組 (3pcs)

- * Suitable for Audi, BMW, Ford, CHRYSLER, OPEL, SAAB, VOLVO, VW, NISSAN, TOYOTA.
- * Fork opening: A: 23mm, B: 55mm
A: 28mm, B: 55mm
A: 34mm, B: 63mm

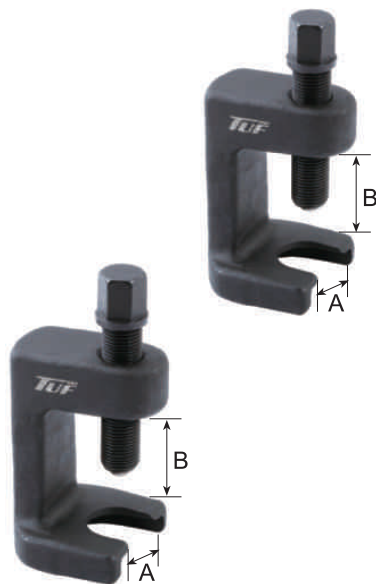

2104 **Ball Joint Separator**
立式球頭拔卸器 (23mm)

- * Suitable for Audi, BMW, CITROEN, Ford, Mercedes, OPEL, PEUGEOT, RENAULT, ROVER, SAAB, VOLVO, VW, Japanese car, etc.
- * Fork opening--A: 23mm, B: 55mm

2105 **Ball Joint Separator**
立式球頭拔卸器 (28mm)

- * Suitable for Audi, A4, A6, A8, VW, PASSAT ab '97, etc.
- * Fork opening--A: 28mm, B: 55mm

2106**Ball Joint Separator**
立式球頭拔卸器 (34mm)

* Suitable for Audi, BMW, Ford, CHRYSLER, OPEL, SAAB, VOLVO, VW, NISSAN, TOYOTA.

* Fork opening--A: 34mm, B: 63mm

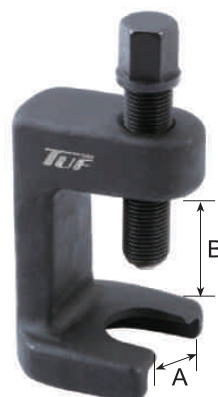

2106



2107

2107**Ball Joint Separator**
雙柱型球頭拔卸器 (23mm)

* For splitting track-rod ends, anti-roll bar mountings, ball joints, etc.

* Fork opening--A: 23mm, B: 45mm

2108**Universal Ball Joint Separator**
可調式球頭拔卸器 (22mm)

* For splitting track-rod ends, anti-roll bar mountings, ball joints, etc.

* Fork opening--A: 22mm, B: max. 62mm

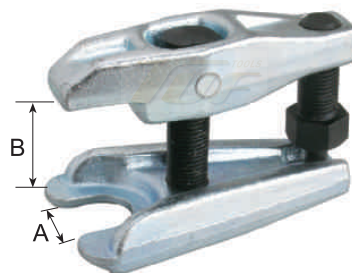
**2109****Universal Ball Joint Separator**
雙用型球頭拔卸器 (17mm)

* For removing the ball pivots on steering arms, steering tie rocks, steering knuckles, etc.

* Fork opening--A: 17mm.

**2110****Universal Ball Joint Separator**
雙用型球頭拔卸器 (20mm)

* For removing the ball pivots on steering arms, steering tie rocks, steering knuckles, etc.

* Fork opening--A: 20mm.

**2111****Ball Joint Separator**
歐式球頭拔卸器 (22mm)

* Special design 2-stage operation suits most cars and light trucks ball joints in steering & suspension.

* Tempered drop forged steel body and offset lever provide an excellent performance and long usage.

* Offset lever permits maximum fork opening in 56mm.

* Fork opening--A: 22mm.





2112

Ball Joint Separator

日式球頭拔卸器 (19mm)

- * It works on most cars and light trucks.
- * Heat treated drop forged steel body & bolt for long rough usage.
- * Spread ball joints easily from the spindle support arm.
- * Fork opening: 19mm.



2113

Ball Joint Separator

日式球頭拔卸器 (可調型)

- * It works on most cars and light trucks.
- * Heat treated drop forged steel body & bolt for long rough usage.
- * Spread ball joints easily from the spindle support arm.
- * Fork opening: 19mm.



2114

Ball Joint Separator

窄型球頭拔卸器

- * Fits many domestic and imported front wheel drive vehicles.
- * Removable pin fits into two pivot points for versatility.
- * The mini operation space: 6-7mm.
- * Fork opening: 19mm.
- * With safety rope to avoid drop while operating.



2115

Outer Tie Rod Remover

兩爪調整式球頭拔卸器

- * Works on imports and domestics, front or rear wheel drives, and castor stamped steel steering knuckles.
- * Two adjustable jaws special designed for removing, most models of outer tie rod.
- * Jaw opening: 100mm, H: 60mm



2116

Pitman Arm Separator

畢特門臂球頭拔卸器 (27mm)

- * Heavy duty forged alloy steel yoke.
- * Heat treated center screw.
- * Remove tie rod ends and pitman arm assemblies from many light trucks.
- * A: 27mm, B: 45mm.

2117

Pitman Arm Separator
畢特門臂球頭拆卸器 (33mm)

- * Heavy duty forged alloy steel yoke.
- * Remove tie rod ends and pitman arm assemblies from many cars and light trucks.
- * A: 33mm, B: 64mm.

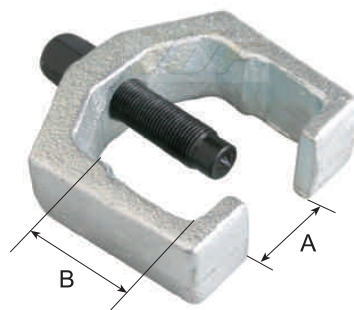

2118

Ball Joint Separator
插式球頭拆卸器 (18mm)

- * 18mm fork, 410mm (L) replaces worn out tie rods easily with a hammer striking.
- * Also can separate shock absorber links.



2119

Ball Joint Separator
插式球頭拆卸器 (24mm)

- * 24mm fork, 300mm (L) replaces worn out ball joints easily with a hammer striking.
- * Also can remove CV drive shafts on FWD vehicles.



2120

Ball Joint Separator
插式球頭拆卸器 (28mm)

- * 28mm fork, 300mm (L) replaces worn out ball joints easily with a hammer striking.
- * Also can remove CV drive shafts on FWD vehicles.



3251

Ball Joint Installer/Remover Tool Kit
賓士前下球頭拆裝組

- * Special design to remove & install the ball joint without removing any parts.
- * Suitable for Mercedes 220/211/230 series.
- * 185mm compression spindle with 24mm hex drive.
- * 2 compression heads 40 and 54mm.
- * 3 pressure pads 22 and 57mm.



3751

Ball Joint Installer/Remover Tool Kit
BMW三角架球頭拆裝組

- * A professional quality tool designed for using easy removal and installation of press fit control arm ball joints.
- * Suitable for BMW 3 series (E36) models.
- * Fine pitch thread drive screw with thrust bearing.





3252 Benz Front Lower Control Arm Ball Joint Installer/Remover Kit 賓士前三角架下控制臂球頭拆裝組

- * Use to remove and install lower ball joint support on the wishbone.
- * On car maintenance.
- * Suitable for Mercedes Benz W124, W129, W201



2034 Special Vibro Chisel Set (for chassis) 車底用氣動錘組

- * Using the special vibro chisel set turns every commercially available compressed air chipping hammer to an ideal problem solver for opening rusted screw connections and for loosening components.
- * The screw loosener chisel attachment loosens screws with different profile effectively and carefully.
- * The strong vibrations of the compressed air chipping hammer are transferred direct to the screw connection whereas a rotating motion is applied using a commercially available wrench at the same time.
- * The hammer mandrel attachment is an amazing support with each extractor procedure (e.g. ball joint pivots).
- * Furthermore, the set includes a pressure plate adaptor for driving out bearings, sleeves, bushes, etc.



2039 Impact Ball Joint Separator Set 氣動球頭拔卸組

- * Fork opening: 42, 35, 30, 24, 20mm



2022 Universal Steering Shaft CV Boot 萬用型方向機防塵套

- * Suitable for most cars.
- * Take CV boot to cover steering shaft through 2023.
- * Contents: CV boot x 1pc, cable x 2pcs, ventilator x 2pcs

2023 Steering Shaft Boot Extending Tool 方向機防塵套擴張器

- * Use with 2022.

2121**Inner Tie Rod Tool Set**
方向機舵桿扳手組

- * Work on the inner tie rods with inaccessible wrench flats.
- * Many inner tie rod end sockets do not have a complete hex on the full length of the socket. The rounded socket ends prevent access to the wrench flats, seven crows feet.
- * Content sizes: 1-3/16", 1-1/4", 1-5/16", 1-7/16", 14mm, 17mm and 33.6mm, to engage the wrench flats. The long socket then slips over the tie rod end and connects to the crowsfoot.

**2007****Multi-Purpose Inner Tie Rod Tool**
方向機舵桿扳手

- * Suitable for track rod joints with $\phi 33-42\text{mm}$.
- * This tool allows quick and easy replacement of the inner track rod joint.
- * Removal of the steering gear is not necessary.

**1143****Steering Wheel Remover/Lock Plate Compressor Kit**
方向盤拆裝組 (18pcs)

- * For steering wheel removal most of automotive & light truck applications.
- * Contents: Steering wheel puller & related bolts.
- * Non-threaded puller legs for late model vehicles with non-threaded hubs.
- * Pivot pin removing tool.

**2122****Flange-Type Puller Combination Kit**
方向盤拆裝組 (雙盤)

- * Two specialty pullers in one box.
- * The flange-type puller for removal of harmonic balancers, timing gears, and other parts with two or three tapped holes.
- * With a steering wheel, pulley, and flywheel puller.

**1151****Turnbuckle for Shock Absorber Top Lid Kit**
綜合型避震器座套筒組

- * The complete sizes for using on most kinds of cars.
- * Contents:
 - -- 2pcs bit: 5, 10mm
 - -- 9pcs bit: 4, 5.2, 6, 6.3, 7, 8, 9, 10, 12mm
 - -- 4pcs bit: 5, 6, 7, 8mm
 - -- 3pcs bit: 3, 3.5, 4mm
 - ★ -- 2pcs bit: T50, T60
 - -- 1pc bit: M12
 - -- 4pcs bit: 8, 9, 10, 11mm
 - -- 9pcs sockets: 14, 16, 17, 18, 19, 21, 22, 24, 27mm
 - -- 5pcs toothed sockets: 10.5, 12.5, 14, 14.5, 14.5





2201 Shock Absorber Piston Rod Tool Kit (19pcs)
避震器座套筒組 (19pcs)

- * For locking the shock absorber piston rod whilst loosening or tightening the piston rod nut, e.g. on Macpherson struts.
- * Suitable for VW-Audi, SEAT, FIAT, VAUXHALL/OPEL, PEUGEOT, RENAULT, BMW, Mercedes, Japanese passenger cars, VOLVO, NISSAN, Mercedes W203.

2202 Strut Nut Tool Set (5pcs)
避震器座套筒組 (5pcs)

- * 10.5mm--VW GOLF rear axle. (7.3 x 3.5mm)
- * 12.5mm--VW POLO front axle. (6.3 x 3.5mm)
- * 14.5mm--POLO, GOLF, PASSAT, Audi 80 (5.3 x 5mm)
- * 14.5mm--AUSTIN MAESTRO. (5.3 x 3mm)
- * 14.0mm--Mercedes Benz, W203 (C-class), W209 (CLK) (2.7mm)



1063 MacPherson Spring Dumper Extractor (Replaceable)
麥花臣避震器彈簧壓縮器

- * Suitable for BMW, TOYOTA, Ford, MITSUBISHI, VW, Audi, SAAB, NISSAN, HONDA, ACCORD, SUBARU, VOLVO, OPEL, PORSCHE.
- * Safety precaution: do not use the impact driver.
- Use range: 80-115mm
- Use range: 110-150mm
- Use range: 140-195mm



1026 Telescopic Compressor for Shock Absorber Springs
賓士避震器彈簧壓縮器

- * Telescopic compressor for shock absorber springs. Suitable for removing and installing helicoidally springs within multi-link, independent arm suspension systems-both front and rear.
- * Supplied with two pairs of interchangeable caps provided with a three-hook safety system.
- * $\phi 70/130$ suitable for Mercedes-Benz (124, 202, 210), SAAB, Ford, SKODA
- * $\phi 90/150$ suitable for Mercedes-Benz (126, 140)100/200, OPEL, GM, LADA, PEUGEOT 405/605 ROVER, HYUNDAI, SAAB, VOLVO, VW, FIAT, MAZDA, TOYOTA, NISSAN, MITSUBISHI, Ford.



2204 Heavy Duty Coil Spring Compressor
爪式彈簧壓縮器

- * Hook engage spring which can be compressed by turning hex nut.
- * Jaws capacity: 23-280mm
- * Length: 280mm

2203

Shock Absorber Spring Compressor

避震器彈簧壓縮器

- * Designed for limited spaces when installing and removing the coil spring at the rear axle.
- * Spring size range: 60-120mm, 120-170mm.
- * Main spindle range: 100-250mm.
- * Compression plate prevents the spring from sliding out.
- * Both top or bottom application is possible.



Coil Spring Compressor

彈簧壓縮器

- * Drop forged carbon steel jaws & Lead screws, both heat treated ensure you obtain professional job performance.
- * Designed for using in limited space under wheel arch.
- * Jaws design is fitting to wrap coil claws for safety.

2205 Maximum jaw opening is 370mm

2206 Maximum jaw opening is 270mm



2207

Multi-Steering Knuckle Spreader Tool Kit

避震器油壓缸座撐開器

- * Spreads the steering knuckle. It enables the removal and installation of the shock absorbers without the risk of damage to the aluminum or cast iron knuckle.
- * Fully adjustable and suitable for steering knuckles with either a centralized or eccentric slot.
- * Wide range of vehicle applications.

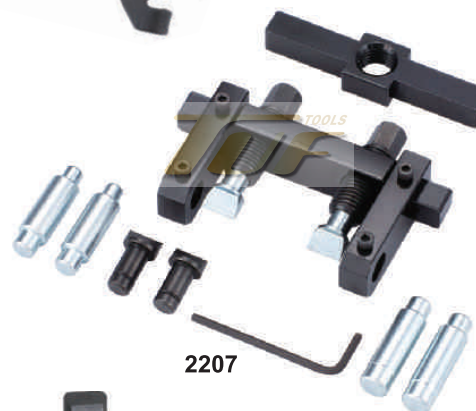

1115

Spreader Socket

避震器油壓缸座撐開器

- * The spreader socket is designed to open out clamping bores. This is essential in order to remove tight suspension strut damper units from the steering knuckle clamping bore. This pry socket enable clamping bores to be opened out without the risk of damaging the steering knuckle. Then, the damper unit can easily be removed and installed without hammer and chisel.
- * Suitable for VW-Audi GOLF (IV), TT, BMW, CITROEN, Ford, SEAT, SKODA, RENAULT, PEUGEOT, Japanese vehicle, etc.



1115



2208

Hook and Pin Wrench Set

活動式勾扳手組

- * Size for 3/4"~2", 1-1/4"~3", 2"~4-3/4"



2208



2301

2302

2303

2304

2301

Hub Slide Hammer Puller

特大型輪軸滑鏈組 (五孔)

- * Extra large internal hole for European car.
- * Coverage with five oval-shaped holes to meet different size of hubs.
- * Increasing the power of pulling with both hands held outside slide hammer.
- * Hammer weight: 6.3kgs

2302

Hub Slide Hammer Puller

特大型輪軸滑鏈組 (四孔)

- * Special designed to pull out the 4 bolts front hub easily with outside hammer.
- * Increasing the power of pulling with both hands held outside slide hammer.
- * Hammer weight: 6.3kgs

2303

Hub Slide Hammer Puller

輪軸滑鏈組 (五孔)

- * Pulls flange-type rear axles on most late model passenger cars & light trucks.
- * Designed to fit axles with bolts & studs up to 9/16" dia.

2304

Hub Slide Hammer Puller

輪軸滑鏈組 (四孔)

- * Pulls 4 bolts of the front hub easily with the 10lb slide hammer.
- * Heavy duty tool for rugged jobs.

2305

Hub Puller

四,五孔輪軸拔卸器

Diameter of disc: 148mm



2305

2306

2307

2306

Front Wheel Drive Axle Puller

傳動軸滑鏈組

Simply secure shaft through opening in the adaptor to remove the half shaft from CV joints on most forward vehicles.

2307

Inner CV Joint Puller

傳動軸滑鏈組 (C型)

- * Fork type tool pulls CV joints with hidden retaining rings & joints on 1986-current TAURUS / SABLE.
- * With this tool the axle assembly is popped out of trans axle without damage to transmission case or inside roller bearing.
- * Fork opening: 48mm

2014

Two-Way Hydraulic Gear Puller 油壓式輪軸拔卸組

- * Capacity: 12 tons.
- * Special safety device design to ensure workers operation.



4501

Compact Wheel Hub/Bearing Unit Kit VW, Audi輪軸總成拆裝組

- * Professional fitting direct on the vehicle (removal with existing wheel hub extractor or universal sliding hammer).
- * Simple and safe handling.
- * Can also be optionally used with a workshop press.
- * Possible extensions for bearing unit $\phi 62$, $\phi 66$, $\phi 72$ mm due to the modular system.
- * Suitable for Audi A2, Audi A2 1.2L, VW LUPO, VW POLO FOX, SEAT IBIZA, SKODA FABIA.



4502

Compact Wheel Hub Kit VW輪軸總成拆裝組

- * Complete tool set for the removal and installation of the compact wheel hub, bearing unit for the VW T5 transporter.



2308

Twist Axle Spindle Rethreading Set (8pcs) 傳動軸螺桿修護組 (8pcs)

- * This tool set accesses axle threads on spindles of eight popular die sizes for both cleaning and rethreading work.
- * When the axle screw is damaged or with rust.
- * Die sizes: M20x1.25, M20x1.50, M22x1.00, M22x1.50, M24x1.50, M24x2.00, 13/16"x2.0 UNEF, 3/4"x20 UNEF.
- * Using with 32mm wrench.



2027

Axle Spindle Rethreading Set 傳動軸螺桿修護組 (9pcs)

- * 9pcs thread restoring die set used to clean or repair axle thread on spindles of M24x2.0, M24x1.5, M22x1.5, M22x1.0, M20x1.5, M20x1.25, 13/16"x20 UNEF, 3/4"x20 UNEF.
- * Using with 32mm wrench.





2028 Reverse Action Wheel Stud Thread Restorer Set
輪胎螺絲修護組 (4pcs)

- * Unique design allows for the two halves of the thread restorer to be fitted on the good thread and wound back over the damaged thread, normally at the end of the stud.
- * Traditional thread restorers rely on luck for the restored and undamaged threads to align.
- * Size: M12x1.25, M12x1.5, M14x1.5



2309 Hose Band Tool with Ratchet
防塵套束裝器 (多功能)

- * Suitable for pre-manufactured and endless hose clips to 9.5mm, for example on CV boots etc.
- * For quick and easy tensioning and cutting endless hose-bands.



2033 CV Joint Banding Tool with Cutter
防塵套束裝器 (附切刀)

- * Use to install and tighten the "band-it" or strap style clamps on CV joint boots, or on power steering rack and pinion steering gear boots.
- * Once installed into the tool, tighten the band by turning the handle on the tool; use a socket or wrench on the handle to torque the hand to OE specifications.
- * When the clamp has been tightened to specs, cut the band to the correct length by flipping the lever (at the front of the tool) forward.



2005 CV Clamp Banding Pliers
防塵套束裝鉗 (固定鉗式)

- * For banding special steel clamps on driver shaft with preset torque reading.
- * Use with 3/8" drive torque wrench.
- * Suitable for VW, Audi, Ford, OPEL...etc.



2311 Clic & Clic-R Hose Clamp Pliers
防塵套束裝器 (虎鉗式)

For removal of clic & clic-R type hose clips fitted to most engines.

2019

Universal Drive Shaft CV Boot 傳動軸防塵套 (萬用型)

- * Suitable for most cars
- * Take CV boot to cover drive shaft through 2020
- * Contents: CV boot x 1pc, stainless clamp x 2pcs, CV joint grease x 1pc.



2020

Drive Shaft Boot Extending Tool 傳動軸防塵套擴張器

- * Use with 2019.



2021

Drive Shaft Boot Extending Tool 傳動軸防塵套輔助器

- * Special "U" type designed to press the boot to end of 2020 easily.
- * Make a round bar to protect the boot without damage.

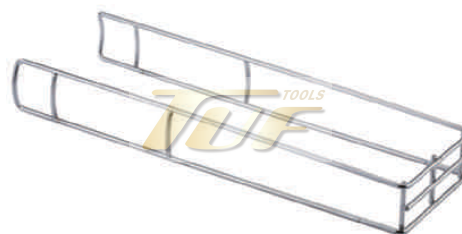

2016

Air Powered CV Boot Installation Tool 傳動軸防塵套擴張器 (氣動式)

- * Innovative tool saves time, money and frustration, installs flexible steering and CV boots without removing axle from the vehicle or the CV joint from the axle. Composite body with simple control valve works from standard workshop air supply. Suitable for cars, small vans, light commercial vehicles.
- * Body: aluminum steel
- * Capacity: $\phi 20-110\text{mm}$
- * Air pressure: 90psi



2035

Blind Hole Bearing Puller Kit 內孔培林拆卸組

- * Open clamps by turning handle clockwise to fit against the bearing for pulling out evenly without damage the parts.
- * Clamps: 8-10mm, 10-12mm, 12-14mm, 15-17mm, 17-20mm, 20-24mm, 25-29mm, 30-32mm.



1054

3-Jaw Internal & External Puller Set 三爪式內外孔培令滑鏈組

- * Small of internal puller 15-30mm, large of internal puller 30-80mm, external puller 15-80mm.
- * Locking the nut to open 3-jaw and clip the bearing, then use the slide hammer to pull out the bearing.





2036 Exhaust Manifold Spring Puller
排氣管C型夾拆裝器

- * It allows any steel springs connecting the exhaust manifolds to the exhaust pipe to be removed and placed.
- * Suitable for Audi, SEAT, SKODA, VW.



2037 Exhaust Hanger Removal Pliers
排氣管橡膠墊拆卸鉗

- * For removing hanger brackets from their rubber mounting straps. Place removal jaw behind the rubber grommet ring and the forcing pin of the pliers on the end of the steel hanger. When handles are squeezed, the forcing pin pushes the ring of the hanger.
- * Suits a wide range of vehicles from cars to light trucks.



2038 Exhaust Donut Stretcher
排氣管橡膠墊拉鉤

Removes and installs rubber mounting ring style hangers. Just place the hook of the tool through the rubber-mounting ring. Then pull or push to stretch until you can remove ring from the hook on muffler, pipe or frame. Reverse the procedure to install ring.



2312 Rim Protective Wheel Socket Set
鋁圈防傷套筒組

- * Thin wall deep impact sockets are designed to allow easy access to recessed wheel nuts where space is limited.
- * With additional outside plastic sleeve to protect the rims when screwing the wheel screws.
- * Size: 1/2" Dr. x 17, 19, 21mm, 85mm (L)
- * Material: Cr-Mo.



2313 Rim Protective Wheel Socket Set
鋁圈防傷套筒組 (4pcs)

- * Thin wall deep impact sockets are designed to allow easy access to recessed wheel nuts where space is limited.
- * With additional outside plastic sleeve to protect the rims when screwing the wheel screws.
- * Size: 1/2" Dr. x 17, 19, 21, 22mm, 85mm (L)
- * Material: Cr-Mo.

2314 1/2" Thin-Wall Middle Deep Impact Socket
1/2"中長氣動超薄套筒組 (3pcs)

- * Size: 1/2" Dr. x 17, 19, 21mm, 55mm (L)
- * Material: Cr-Mo.



2315 1/2" Thin-Wall Deep Impact Socket
1/2"長氣動超薄套筒組 (4pcs)

- * Size: 1/2" Dr. x 17, 19, 21mm, 78mm (L), H12, 60mm (L)
- * Material: Cr-Mo.



3253 Wheel Lug Socket
賓士輪胎專用套筒

- * For MAYBACH, W221 (S-class) and late CL-class Mercedes which with unique convex lug bolts.
- * Size: 1/2" Dr. x 17mm, 45mm (L)



2030 Valve Core Remove / Installer Tool (with Clip)
氣門心起子(附夾)

- * For Installation and removal of standard valve cores.
- * Has a screwdriver-style handle.
- * Tip length: 50mm



2031 Valve Core Remove / Installer Tool (with Clip)
長型氣門心起子(附夾)

- * For Installation and removal of standard valve cores.
- * Has a screwdriver-style handle.
- * Tip length: 180mm



2032 Snap in Tire Valve Installer
氣門風嘴拉拔器

- * Steel constructed tool deep threaded head for positive sealing of all snap-in type passenger car tire valve stems.
- * Rubber cover design to protect the rim.





1094

Rim Protector

輪胎鋁圈保護墊 (2pcs)

To protect the wheel rims from damage.



2004

Balancing Weight Pliers

鉛子鉗

- * For removing & installing wheel weights.
- * The drop forged heat treated tool is balanced and heavy enough to swing like a hammer.
- * Designed for tough usage.



1001

Insert Split Eye Tool

補胎條用補胎針 (鐵柄)

- * Align split eye tool with memorized direction / angle. Insert split eye tool into the hole.
- * Durable metal T handle design.
- * Cr-Mo steel needle
- * Needle length: 60mm
- * Changeable needle design.

1001L

Insert Split Eye Tool

補胎條用補胎針 (加長型)

- * Align split eye tool with memorized direction / angle. Insert split eye tool into the hole.
- * Durable metal T handle design.
- * Cr-Mo steel needle
- * Needle length: 74mm
- * Changeable needle design.

1002

Rotate Rasp Tool

補胎條用補胎鑽 (鐵柄)

- * Align rasp tool with memorized direction / angle. Rotate rasp tool slightly. Rasp tool will find the hole direction naturally.
- * Durable metal T handle design.
- * Needle length: 82mm
- * Changeable needle design.

1168 **Tire Seal Strip**
補胎條

- * Vulcanized tire seal strip fits tire fixing forever.
- * The seal made by the way of pressing to make the surface regular and closely.
- * Contents: 25 strips of 5 pieces.
- * The rubber seal will be reassembled when the temperature reach 85°C.
- * Length: 9"



2010 **Round Tube Patch**
補胎片

- * Size: 2010-32-φ32mm, 2010-42-φ42mm, 2010-50-φ50mm
- * Package: 100pcs / box



1169 **Rubber Cement**
補胎膠水

Volume: 250cc

2018 **Roller Stitcher**
木柄補胎滾輪工具

- * Wood handle for light and portable.
- * Bearing inside for using easier.



2316 **Tire Lever**
輪胎撬棒

- * Made from forged alloy steel hardened and tempered.

Sizes:

- 2316-20 L: 200mm
- 2316-30 L: 300mm
- 2316-53 L: 530mm
- 2316-53B Bent type L: 530mm
- 2316-65B Bent type L: 650mm



1051 **Magnetic Adjustable Camber Gauge**
水銀錶

- * It has a simple leveling adjustment of $\pm 6^\circ$
- * Housed in a durable, non-magnetic casing with a magnetic head that attaches firmly to rotors or spindles.
- * This is a time and money saving device.
- * Return a strut to its original camber after repair or replacement.
- * Measure camber change before reinstalling alignment heads during camber kit installation.
- * Check the amount of camber change before reinstalling tire and wheel assemblies on trucks.





2401 Wheel Alignment with Digital Protractor
 大王梢檢查錶 (電子式)

- * Perform portable, no heavy turntable! One person operation.
- * Display camber: caster, KPI, toe
- * Includes gauge and wheel mount (from 10" to 20")



2009 Speedy Brake Piston Spreader
 碟式剎車調整器 (快速型)

- * To quickly spread brake pads and compress disc brake pistons for pad replacement on single, double and quad piston calipers.
- * Simultaneously compress all four pistons on quad piston applications.
- * Can be used while the caliper is on the vehicle or hanging free.
- * Makes brake pad replacement a quick and easy job.



2017 Disc Brake Piston Spreader
 碟式剎車調整器

- * For brake caliper service to push back pistons for new brake pads installation.
- * Pad width: 50mm.



1106 Disc Brake Spreader
 碟式剎車調整器 (四活塞)

- * Heavy duty drop forged tool.
- * For brake caliper service to push back pistons for new brake pads installation.
- * Pad width: 88mm.



2403 Brake Spring Pliers
 剎車彈簧鉗 (小車)

- * Makes relining drum brakes easy.
- * Deep jaws clear shoe and strong hook holds spring securely.
- * Handle ends remove and install anchor springs.

1097**Universal Caliper Wind Back Kit (21pcs)**

剎車分泵調整組 (21pcs)

- 1-1: Right hand helix bolt
- 1-2: Left hand helix bolt
- 2: Suitable for CITROEN/XM/XANTIA (F/R)
- 3: Suitable for Audi (F), FIAT/ALFA ROMEO (F), Ford/FIESTA (F), ISUZU (F), HONDA/CONCERTO (F), JAGUAR/XJ6/ XJ40 (F/R), BMW/318is/320i/325TD/518i/525i & 1x/740i/850ci/M5 (F), Mercedes Benz/190/200/300/420/560 series (F), MITSUBISHI/COLT (F), NISSAN/MLERA/STANZA/SUNNY (F), ROVER/AUSTIN, METRO 200 & 400 series, MAESTRA, MONTEGO (F), TOYOTA/CAMRY (F), VOLVO (F), VW/PASSAT, GOLF GTI (F).
- 4: Suitable for Ford AUSTRALIA/NZ TELSTAR, LASER (R), MAZDA (R), SAAB 9000(R), FIAT/ALFA ROMEO1642.0 (R), HONDA/PRELUDE, CRS 16i, GM/SATURN (R), GM/GRAND PRIX, LUMINA.
- 5: 3/8" Dr. adaptor used with extension bar and ratchet when need to apply more strength to the piston.
- 6: Suitable for NISSAN, PRIMERA, VW/GOLF IV.
- 7: Suitable for Audi/80/90/V8+100, COUPE E (R), ROVER/800 ABS, SUBARU L+Z (R), Ford/SIERRA ABS, GRANADA, SCORPIO ABS 85 (R), NISSAN/BLUEBIRD 1.8 TURBO, SILVIA TURBO, PRIMERA 2.0i LS/GS/GSX (R), PEUGEOT/405 1.9Gi/ Gri/Sri/Gtxi, MI 16,605 2.0 Sri (R), TOYOTA/CELICA, COROLLA GT, MR2 (R), VW/GOLF GTI, JETTA SYNCRO, JETTA GTI 16V, PASSAT CL, GL, GT & GT 16V, CORRADO 16V SCIROCCA GTX 16V (R).
- 8: Suitable for GM most 1-7/8" diameter pistons.
- 9: Suitable for GM most 2-1/8" diameter pistons (CADI SEVILLE/ELDORADO 80-85).
- 0: Suitable for GM most 2-1/2" diameter pistons (SEVILLE/ELDORADO 79).
- A: Suitable for RENAULT/R21, LAGUNA (rear disk).
- M: Suitable for Ford Motors MINI COOPER.
- N: Suitable for SAAB, HONDA.
- F: Suitable for OPEL (rear disk).
- E: Suitable for NISSAN MAXIMAS
- K: Suitable for CITROEN
- K1: Suitable for CITROEN
- M2: Suitable for CITROEN

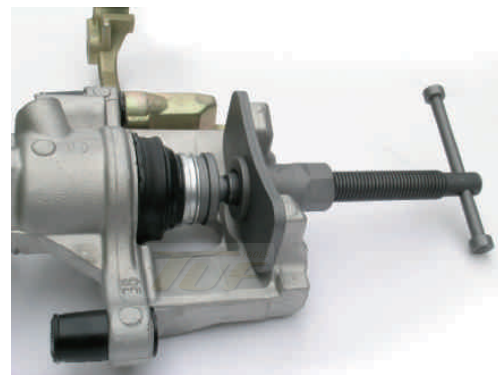
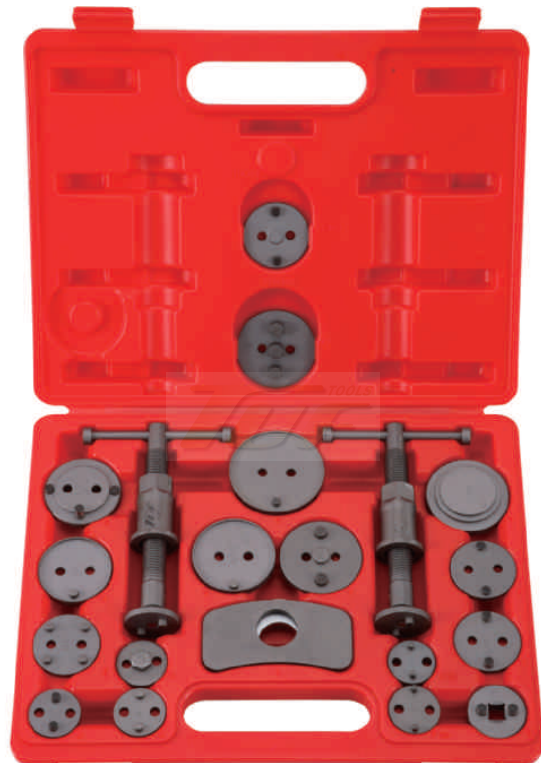
**2402****Air Disc Park Brake Calipers Tool Kit**

剎車分泵調整組 (氣壓式)

- * Air powered brake caliper wind back tool
- 0: Suitable for GENERAL MOTORS
- 2: Suitable for CITROEN, XM, XANTIA u.a.
- 3: Suitable for ALFA ROMEO, Audi, AUSTIN, BMW, Ford, HONDA, JAGUAR, MITSUBISHI, Mercedes-Benz, NISSAN, ROVER, TOYOTA, VW
- 4: Suitable for ALFA ROMEO 164 2.0, Ford, MAZDA, SAAB 9000, SUBARU
- 5: Adaptor with 3/8" inner 4-pt.
- 6: Suitable for NISSAN PRIMERA, VW-GOLF IV
- 7: Suitable for Audi 80/90/V8+100, Ford SIERRA ABS+SCORPIO AB 85, HONDA PRELUDE, NISSAN SLIVIA 1.8 TURBO, ROVER 8000, SAAB 9000, SUBARU L+Z, VW-GOLF+PASSAT
- 8: Suitable for GENERAL NOTORS
- P: Suitable for GENERAL NOTORS
- Z: Suitable for RENAULT
- E: Suitable for NISSAN, MAXIMA
- G: Suitable for OPEL
- 10: Suitable for CITROEN
- 11: Suitable for KIA HYUNDAI
- 12: Suitable for Ford MONDEO
- 13: Suitable for SAAB, HONDA
- 14: Suitable for CITROEN C5
- 15: Suitable for RENAULT MASTER





1128 **Disc Brake Cylinder Hone**
三爪內孔研磨器 (64mm)

- * Adjustable tension hone size fits cylinders 19-64mm
- * 3 stones 28mm medium grit.



2404 **Gauge for Brake Disc & Tyre Depth**
剎車盤厚度胎紋深度規

- * Special device to fix the value you obtain while you measuring the thickness of brake disc.
- * Brake disc measure range: 0-60mm
- * Measure type depth



2405 **Brake Fluid Tester**
剎車油測試器

- * Use the tester as quick reference to the moisture content of the brake fluid.
- * LED read out indicates quality of brake fluid.



1025 **Pocket Brake Fluid Tester**
剎車油測試器 (簡易型)

- * The tester can be a digital brake fluid tester suitable for determining brake fluid quality.
- * Quality is tested and indicated on five LEDs in terms of "percent of water in the brake fluid"



3752 **BMW Silentbloc Tool Kit**
BMW綜合鐵套拆裝組

- * Suitable for 1 series: E81, E87
- * Suitable for 3 series: E36, E46, E83, E90, E91, E92, E93
- * Suitable for 5 series: E39, E60, E61, E70
- * Suitable for 6 series: E63, E64
- * Suitable for 7 series: E38, E65, E66, E67
- * Suitable for 8 series: E31, E52
- * Suitable for Z4: E85, E86
- * Suitable for MINI COOPER S: R53

3753**BMW Rear Trailing Arm Bush Tool Kit**
BMW後三角架鐵套拆裝組

- * For the easy removal and installation of the rear trailing arm bushes (33321097009) as fitted to BMW 3 series models - E36, E46 & E46 compact.
- * Suitable for removing original bushes and removing & installing new style "slotted" bushes (33321097009) - in situ without removing the rear trailing arm.

**3754****BMW Rear Sub-Frame Bush Tool Kit**
BMW工字樑鐵套拆裝組 (X5)

- * Bush replacement tool for use on rear axle carrier bushes (33311093662) as used on BMW X5 series models.
- * The tool features a fine pitch thread and thrust bearing to enable the rear sub-frame bush to be removed / installed - without removing the rear sub-frame assembly from the vehicle.

**3755****BMW Rear Sub-Frame Bush Tool Kit**
BMW工字樑鐵套拆裝組

- Bush replacement tool for use on rear axle carrier bushes (33311091422) as sub-frame bush to be removed / installed - without removing the rear sub-frame assembly from the vehicle.

**3756****BMW MINI Front Control Bush Tool Kit**
BMW MINI前三角架鐵套拆裝組

- * Remove/install BMW MINI control arm bush.
- * Can be used in situ - no need to remove trailing link assemble from vehicle.
- * Suitable for MINI CCOOPER R50/R52/R53, CHASSIS W10/W11/W17.

**4503****VW, Audi Silentbloc Tool Kit**
VW, Audi綜合鐵套拆裝組

- * The silentbloc tool kit is developed for removal and installation.
- * Suitable for Audi - A3, S3 (2004-2012), TT, TTS COUPE/ROADSTER (2007-2012)
- * Suitable for SEAT - ALTEA (2004-2012), LEON (2006-2012), TOLEDO (2005-2009)
- * Suitable for VW - GOLF 5 PLUS, VARIANT, 4 MOTION (2005-2012), JETTA, SYNCRO (2006-2012), SCIROCCO (2009-2012), BEETLE (2012), EOS (2006-2012).





4504 **VW, Audi Silentbloc Tool Kit**
VW, Audi後三角架鐵套拆裝組

* Suitable for installation and removal of rubber-plastic bearings or rubber-metal bearings at the rear axle.
 * Suitable for Audi A3, VW GOLF 4, BORA, NEW BEETLE



4505 **VW Silentbloc Tool Kit (T5)**
VW 後三角架鐵套拆裝組 (T5)

For removal and installation silentbloc bushings on VW T5 rear axle.



4506 **VW Rear Axle Bush Remover/Installer Kit (POLO)**
VW後三角架鐵套拆裝組 (POLO)

* Suitable for VW POLO/ FOX, SEAT IBIZA, CORDOBA Y, SKODA FABIA REF.
 * OEM: T10030, T30035, 3301 Y 473

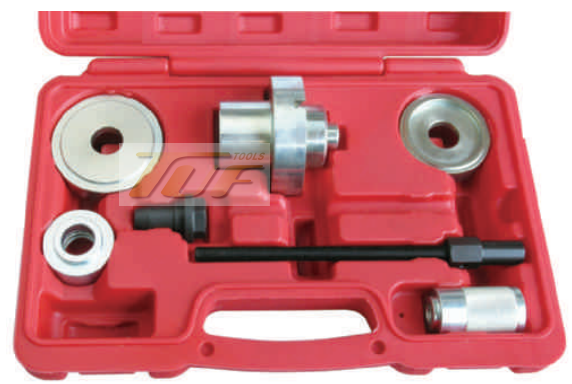

4507 **Silentbloc Remover/Installer Tool Kit**
VW, Audi三角架鐵套拆裝組

* The silentbloc in the bracket can quickly and safely be removed and installed directly on the vehicle.
 * Suitable for VW POLO (9N), SEAT IBIZA, CORDOBA (2002 onwards), SKODA FABIA, ROOMSTER and Audi A2 front-axle bracket wishbone.

4508

VW Suspension Bush Tool Kit
VW仰角鐵套拆裝組

- * Special tool for replacing the front suspension bushes on VOLKSWAGEN POLO from 2002 onwards. Replacements are available for the bolt and bar which are considered consumable.
- * Suitable for VW POLO 2002 later.



4509

VW, Audi Bush Remover/Installer Kit
VW, Audi鐵套拆裝組

- * Special design to remove and install the bush.
- * Suitable for VAG series.



4510

VW, Audi Rear Axles Bushing Tool Kit
VW, Audi 後三角架鐵套拆裝組

- * Special designed for replacing the rear axle mounting bushes, whilst in situ on the vehicle and without the need for removing the rear axle assembly.
- * It is fine thread and thrust bearing allows the bush to be fitted quickly and easily without causing damage.
- * Suitable for Audi A3, VW GOLF IV, BORA 1.4/1.6/1.8/2.0 and 1.9d (2001-2003)



2501

Ford Rear Axle Bush Tool Kit
工字樑鐵套拆裝組

- * Remove and install rear sub-frame bushes on Ford FOCUS.
- * Can be used in situ no need to remove sub-frame from vehicle.

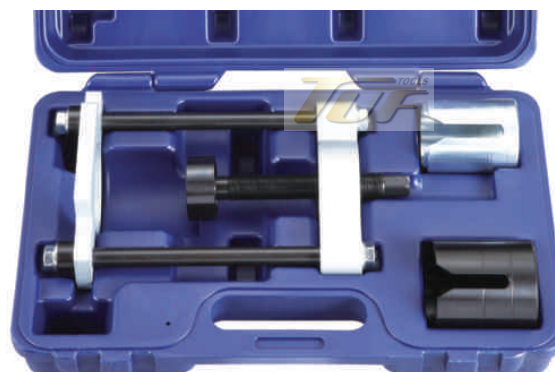



1049 Fwd Front Wheel Bearing Tool Kit (23pcs)
 仰角培令拆裝組 (23pcs)

- * A great tool used to replace front wheel bearings without removing the steering knuckle & strut assembly.
- * As the spindle assemble without removed there is no need to align front end after the job is done.
- * Fit on most cars.
- * Could be worked with shop press also.



1123 Fwd Front Wheel Bearing Tool Kit (15pcs)
 仰角培令拆裝組 (15pcs)

- * A great tool used to replace front wheel bearings without removing the steering knuckle & strut assembly.
- * As the spindle assemble without removed there is no need to align front end after the job is done.



2008 Press and Pull Sleeve Kit
 鐵套拆裝組 (通用型)

- * Universal tool kit for extracting and drawing in silent bearings, hydraulic bearing, bearing bushes, ball bearings, shaft seals, rubber bearings, etc.
- * Fully universal application. Ideal for different vehicles. Car+HGVs.
- * Depending on requirements, the particular sleeves can also be individually reworked.
- * Application also with workshop press+press frame.
- * 20pcs press-on sleeves.
- * Inside: ϕ 34, 36, 38, 40, 42, 44, 46, 48, 50, 52, 54, 56, 58, 60, 62, 64, 66, 68, 70, 72mm
- * Outside: ϕ 44, 46, 48, 50, 52, 54, 56, 58, 60, 62, 64, 66, 68, 70, 72, 74, 76, 78, 80, 82mm
- * 4pcs pulling spindle + nuts, size: M10, M12, M14, M16



2502 Extra Large Custom Built Bush/Bearing/Seal Driver Set
 鐵套，培令，油封拆裝套件組 (21pcs)

- * This extra large driver set allows you to build your own custom bushing driver. Select the required sizes and assemble your driver tools.
- * Discs are connected with a shaft and screw which connects to the driver handle.
- * Build to suit the required seal bush or bearing job.
- * Disc size: 70-150mm in 5mm increments.

2006

Custom Built Bush/Bearing/Seal Driver Set
鐵套，培令，油封拆裝套件組 (52pcs)

- * This master set allows you to build your own custom bushing driver. Select the required sizes and assemble your driver tool.
- * Build to suit the required seal, bush or bearing job.
- * Disc size: 18-65mm in 1mm increments and 74mm.



1056

Bearing Race & Seal Driver Set
斜型培令套安裝組

- * Quickly & easily inserts wheel bearing races & seals without damage to race & axle housing.
- * 7 disc sizes for most standard wheel bearing.
- * The flat surface of the 7pcs disc can drive seals evenly.
- * Size: 39.75, 44.45, 49.91, 59.05, 62.73, 64.8, 52.1mm



1057

Bearing Race & Seal Driver Set
斜型培令套安裝組 (小型)

- * Quickly & easily inserts wheel bearing races & seals without damage to race & axle housing.
- * Contents:
 - 13pcs adaptor--10, 12, 14, 15, 16, 18, 19, 20, 22, 25, 26, 28, 30mm
 - 3pcs driver handle--115, 140, 160mm (L)

