

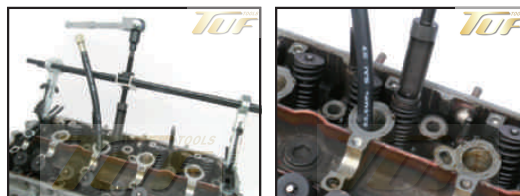

1160 One Man Operation Valve Spring Compressor Kit 單人操作免拆式凡而鉗組

- * The valve pusher master is adjustable/shifting by 2 bars and lockable to fit various angle of valve on engines.
- * The user's hands are spared for precious operation onto valve spring compression and on small parts collection/replacement.
- * 2pcs--Valve pusher, $\phi 22 \times 75$, $\phi 22 \times 125$, for expanding the tool capacity for various engine types.
- * Large work window of valve pusher to supply more space for replacing valve collets.
- * No need to remove the cylinder.



1109 Valve Spring Compressor Kit 免拆式凡而鉗組

- * Complete service tool kit for installation and removal of the valve spring without removal of cylinder head from the engine.
- * Suitable for OHV & OHC petrol/diesel engine on Audi, NISSAN, TOYOTA, CHRYSLER, HONDA, MAZDA, MITSUBISHI, PORSCHE, VOLVO, VW.

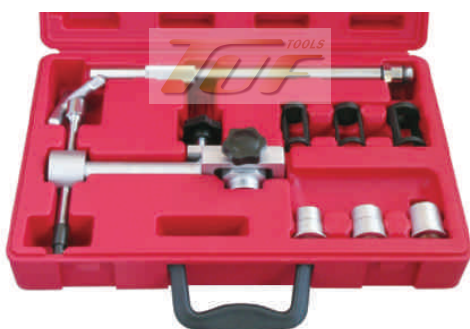

1501 Valve Spring Compressor Kit 快速型免拆式凡而鉗組

- After removing a spark plug, insert the relevant adapter into a plug hole, screw and firmly fix the support at the thread plug hole. Assemble the body to the support adjust the angle adjuster in accordance with an angle of a valve.
- Fasten the body, using the body fastener, move the distance adjuster so as to set the distance between the valve and the body, then remove air inlet, mount the pushing member on the valve, and revolve the pusher to push the valve down.



1046 Valve Spring Compressor Kit 螺桿型凡而鉗組

- * Used for car & motorcycle.
- * Pusher size: 16, 19, 23, 25, 30mm
- * 5pcs pusher for fitting the valve spring correctly and easier to compress the valve spring.

1047**Valve Spring Compressor**

萬用型凡而鉗

- * Reversible jaw adaptor for multi-valve engines.
- * Capacity 45-145mm, 250mm big jaw adaptor for easy replacement of valve collects.
- * Size: dia. 25, 30mm.

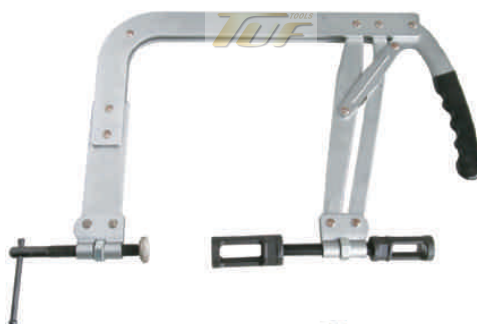
**1502****Overhead Valve Spring Compressor**

下壓式凡而鉗

- * For using on a wide range of OHV, OHC and CHV engines.
- * Not suitable for using on engines with deep seated valves.
- * Allow valve springs and valve stem oil seals to be replaced with the cylinder head.
- * A reversible jaw/adaptor and automatic cam-action locking to a re-determined setting.

1147**Universal Overhead Valve Spring Compressor**

小型凡而鉗

- * Permit removal and installation of valve springs without removing the cylinder head on cars and light trucks.
- * Spring loaded offset jaws easily grip and compress valve springs.

**1050****Valve Seal Removal & Installer Kit**

氣門油封拆裝組

- * Work on valves still seated or removed.
- * Precision machined seal driving adapters guide the seal for proper setting.
- * 1pc--Valve stem seal pliers, 270mm(L)
- * 1pc--Drive handle 6"/150mm(L)
- * 2pcs--Deep seal driving sockets, for seals O.D. 10.8-14.8mm.
- * 7pcs--Seal driving adapter, for seals 5, 5.5, 6, 6.6, 7, 8mm, 3/8".

**1006****Valve Stem Seal Pliers**

氣門油封拔取鉗(長型)

Long neck designed to reach into confined area of the seal to grip it for removal. Gripping serration grasps both original equipment & aftermarket seals regardless of the configuration.





1503 **Valve Stem Seal Pliers**
氣門油封拔取鉗

Designed to reach into confined area of the seal to grip it for removal. Gripping serration grasps both original equipment & aftermarket seals regardless of the configuration.



1429 **Valve Stem Seal Remover**
深孔型氣門油封拔取器

- * Superior to remove valve stem seal without any risk of damage to inner walls of the cylinder-head in the area of the bucket-tappet.
- * Tri-jaw pinching designed to grip seal outer diameter from 10-19mm.
- * Slider hammer with rough texturing prevents hand-slippage.
- * Twin-color finish (nickel plating in jaws & black finished in body) benefits stem valve lock-in.



1504 **Valve Collet Installing & Pick Up Tool Set**
氣門彈簧半圓形固定銷安裝器

- * This tool holds the valve keepers in its magnetic jaws so you can easily move the keepers into the valve stem grooves for installation.
- * Easily reaches into recessed spring pocket to retrieve released valve keepers.
- * Retrieves small parts from any recessed or hidden area.



1422 **NISSAN Valve Adjusting Tool**
NISSAN氣門墊片更換鉗

Shim pliers push the shim between the valve lifter ledge and camshaft for easy replacement. Includes wedge tool for NISSAN SENTRA, GM engines.



1423 **TOYOTA Valve Adjusting Tool**
TOYOTA氣門墊片更換鉗

Shim pliers push the shim between the valve lifter ledge and camshaft for easy replacement. Includes wedge tool for TOYOTA engines.

Piston Ring Pliers 活塞環撥開鉗

ITEM NO.	RANGE (mm)	ITEM NO.	RANGE (mm)
1507	50-100	1509	110-160
1508	80-120		

- * Designed for fitting and removing piston rings without damage.
- * Pressure on the handles opens the ring which is retained in the jaws by the side hooks.
- * Once the pressure is released the ring enters into the piston groove.
- * A transverse spring closes the tool when the piston ring is not inserted.



1424 Piston Ring Installer 活塞環撥開鉗

Save by reducing ring breakage. Tapered jaws to remove and install most of passenger car and light truck rings from 83-135mm.



1435 Piston Ring Installer 小型活塞環撥開鉗

Save by reducing ring breakage. Tapered jaws to remove and install most of passenger car and light truck rings from 1.2-6.3mm.



1506 Piston Groove Cleaner 活塞環槽溝清除器

- * Provided with 4 cutter blades to fit different groove sizes. Turning the handle adjusts the tool to the required diameter.
- * Fits 50-175mm diameter pistons.
- * Blades size: 2/2, 5/3/3, 5mm



Piston Ring Compressor 活塞環夾

ITEM NO.	HEIGHT (inch)	CAPACITY (mm)	ITEM NO.	HEIGHT (inch)	CAPACITY (mm)
1075	3	53-125	1077	4	90-175
1076	3	90-175	1087	6	90-175

- * Designed for rapid insertion of pistons into the cylinders. The square adjustment key forces the rings into the grooves and a clutch control prevents them from expanding.
- * Different heights and diameters for the various sizes and number of rings.





1510 **Piston Ring Compressor Kit**
 活塞環夾鉗組

- * Includes pliers and six bands (73-79, 79-86, 86-92, 92-98, 98-105, 105-111mm).
- * Use the pliers with any band to install pistons.
- * Self-locking ratchet allows you to compress rings by minute graduation. Pliers can be used vertically or horizontally.



1129 **Engine Cylinder Hone**
 三爪內孔研磨器

- * Fits cylinders 2" to 7" (50-175mm)
- * 3 medium grit stones 4" (100mm) long for quick polishing or honing.
- * Flexible driver gives good stability without cutting.

1161 **Air Operated Valve Lapper**
 氣動凡而研磨器

- * Designed for operating in tough environments.
- * Adjustable speed regulator for precise control during operation.
- * Complete with rubber caps of 20, 30, 35, 45mm.



1407 **Valve Compressor Extension Tube**
 氣缸壓力延長接管

- * Special design to extension the spark plug thread in the deep hole for easier testing.
- * Thread: M12 x 1.25
- * L: 235mm



1408 **Valve Compressor Extension Tube**
 氣缸壓力延長接管

- * Special design to extension the spark plug thread in the deep hole for easier testing.
- * Thread: M14 x 1.25
- * L: 235mm

1511**Extra Long Internal Spark Plug Rethread Tool
長型火星塞孔修牙器**

- * Special designed for chasing spark plug threads from inside the cylinder head and working outward.
- * Use the good threads at the base of port.
- * Reduced dirt and metal debris from being driven into the cylinder head.
- * Thread: M12 x 1.25

**1512****Extra Long Internal Spark Plug Rethread Tool
長型火星塞孔修牙器**

- * Special designed for chasing spark plug threads from inside the cylinder head and working outward.
- * Use the good threads at the base of port.
- * Reduced dirt and metal debris from being driven into the cylinder head.
- * Thread: M14 x 1.25

**Pipe Threaded Coil-Insert Repair Kit
(for Spark Plug Thread) 火星塞孔修護組**

ITEM NO.	MAIN TOOL	SCREW-COIL	TAP	COIL INSTALLATION SHANK	COIL SHIELDING COLLAR (INTERNAL THREAD)
1515	M10x1.25	M10x1.25x1.5D (L: 15mm)x 5pcs	M10x1.25	M10x1.25	M10x1.25
1516	M12x1.25	M12x1.25x1.5D (L: 18mm)x 5pcs	M12x1.25	M12x1.25	M12x1.25
1517	M14x1.25	M14x1.25x1.5D (L: 20mm)x 5pcs	M14x1.25	M14x1.25	M14x1.25

**1071A****Gasoline Cylinder Compression Tester Kit
汽缸壓力錶組 (簡易型)**

- * Air gauge with quick coupling & release valve.
- * High-tension connecting pipe with safety lock coupling.
- * Crank shaft type test pipe with rubber plug.
- * Transverse axis test pipe with rubber plug.

**1071****Gasoline Cylinder Compression Tester Kit
汽缸壓力錶組**

- * Air gauge with quick coupling & release valve.
- * High-tension connecting pipe with safety lock coupling.
- * Crank shaft type test pipe with rubber plug.
- * Transverse axis test pipe with rubber plug.
- * Includes gauge (0-300psi), rubber test hose, steel test hose, straight steel test hose.
- * 4pcs adaptor: M10x1.0, M12x1.25, M14x1.25, M18x1.5.





1302 **Cylinder Leakage Tester Kit**
汽缸測漏組 (氣壓式)

- * Quickly locate internal engine problems such as bad rings, valves and leaking head gaskets.
- * Dual 2.5" heavy duty gauges with rugged protective outer boots.
- * One gauge reads 0-100psi and 0-7 bar and the other reads percentages.
- * Pressure regulated manifold includes high quality quick couplers for fast set-ups.
- * Includes: dual 2-1/2" gauges, pressure range: 0-100psi / 0-7bar, rubber protector, 26" hose with 14mm & 18mm adaptor fittings.



1126 **Cylinder Base Surface Rectifier**
汽缸床平面量規

- * Straight edge works for precision check the cylinder damage or not.
- * Length: 600mm, width: 36mm, height: 16mm.



1113 **Torque Angle Gauge**
1/2" 扭力角度規

- * Required when serve many latest model engines that use torque-to-yield fasteners. Measures angle of rotation after pre-torque in torque-angle applications.
- * The 360° scale is marked in 2° increments and intervals of 10° and 30°; easily zeroed for next application by turning the tool housing.
- * With 1/2" male and female square drives.



Steel Torque Angle Gauge
扭力角度規 (鐵製)

- * These tools are designed to tighten bolts and nuts to a predetermined load by measuring the torque angle, as specified for many part of car and truck engines. It incorporates a female and male square drive which is engaged into a graduated ring. A small bracket sliding around the crown of the graduated scale allows easy setting of the reaction lever. Value "0" in the graduated scale is provided by a click. We recommend using this tool with accessories of sockets.
- * **1144** -- 1/2x1/2 SQUARE DR. (inch)
- * **1513** -- 3/4x3/4 SQUARE DR. (inch)

1514 **Torque Angle Gauge with Clip**
扭力角度規 (附夾子)

- * Surface scale is 360°; minimum is 2°. It can be set by right or left.
- * Flexible hose can be used in curve space, all length is 418mm. The front end has a powerful magnet, so easy to fix on every position.
- * Operated by 1/2" wrench will be more convenient owing to appropriate distance between axle center and scale plate.
- * change the magnet to the clamp for fixing on every position.

1121**Crank Seal Remover / Installer Kit****凸輪軸曲軸油封拆裝組**

- * Allows the crank seal to be replaced without dismantling the crank case.
- * Prevents scraping the crank surface that may be caused by using other removal methods.
- * Universal use covering a wide range of cars with oil seals between 27mm and 58mm in diameter.
- * Use the existing bolt in the vehicle for installation.
- * Screw-type adapter to fit the centering
- * The blue seal adapters are made of aluminum to prevent the damage of crank.
- * Long hooks 114mm.

Note: Some cam seals have screws to prevent remove. Do not attempt to use this tool by force.

**1052****Seal Puller****T型油封拆卸器**

- * Easily removes grease and oil seals.
- * Red vinyl, non-slip handle.
- * 2 tips for multiple applications.

**1146****Hook & Pick Set (5pcs)****小型油封拉拔器組 (5pcs)**

- * Stainless steel points.
- * Set contains awl, hook tool, 45° & 90° bent tool.
- * Use for detail works and scribing, picking jobs.

**3006****Benz Rear Crankshaft Radial Sealing Ring Installer****賓士後曲軸油封安裝器**

- * The crankshaft radial sealing ring has both a lip and a protective lip.
- * They can not be damaged when assemble the cover to the crankshaft flange.
- * This tool is designed to prevent damage when assemble the cover to the crankshaft flange.
- * Suitable for Mercedes Benz M272, M271.

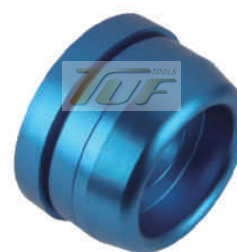
**3501****BMW Engine Timing Tool Kit (N42/N46/N46T)****BMW正時工具組 (8pcs)**

- * For adjustment and arresting of the twin camshaft on petrol engines. Engine timing checking and adjustment. VANOS unit: removal, installation and alignment.
- * Easily accessible operating instructions including cross references to original part numbers.
- * Suitable for BMW 118i/120i N46 engine, 316i/316ti/318ti N42 engine, 318i/320i/N46 engine, Z4, 2.0i N46, X3 (2001-2010).

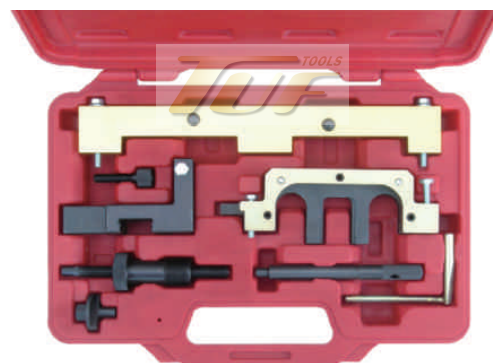

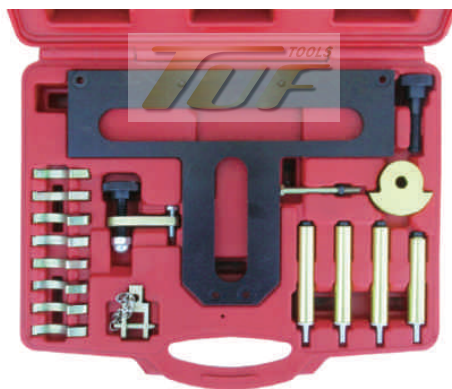

3502 BMW Engine Timing Tool Kit (N42/N46)
BMW正時工具組 (18pcs)

- * Suitable for the following application: camshaft installation and removal as well as removal and installation of the inlet camshaft and carrier assembly valvetronic system.
- * Easily accessible operating instructions including cross references to original part numbers.
- * This kit needs to use with 3501.
- * Suitable for BMW 118i/120i N46 engine, 316i/316ti/318ti N42 engine, 318i/320i/N46 engine, Z4, 2.0i N46 engine.

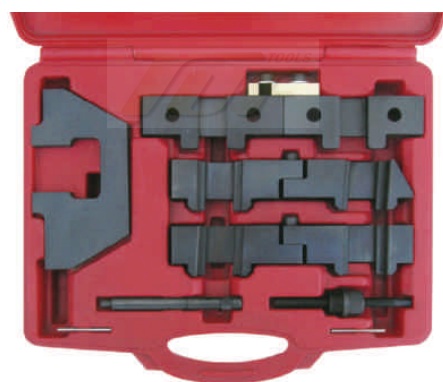

3504 BMW Camshaft Alignment Tool Kit
BMW正時工具組 (全車系)

- * BMW engine models M42 & M50: includes 2 block swivel lock plate & locking pin for setting camshaft timing.
- * Engine models M40 & M70: include plate & locking pin for setting camshaft timing.
- * BMW engine M60 & M62: includes 2 block swivel lock plate & locking pin for setting camshaft timing.



3506 Camshaft Alignment Tool Kit
BMW正時工具組 (M40)

- * Two popular tools brought together to service a wide range of older BMW petrol engine vehicles.
- * Both belt driven and chain driven engines are covered.
- * Suitable for BMW engine models M40, M70.



3507 Camshaft Alignment Tool Kit
BMW正時工具組 (M50)

- * Includes: 2 blocks, swivel lock & locking pin, for setting camshaft timing.
- * Suitable for BMW engine models M42 and M50.

3508**Camshaft Alignment Tool Kit**

BMW正時工具組 (M60)

- * Includes: 2 blocks, swivel lock & locking pin, for setting camshaft timing.
- * Suitable for BMW engine models M60 and M62.

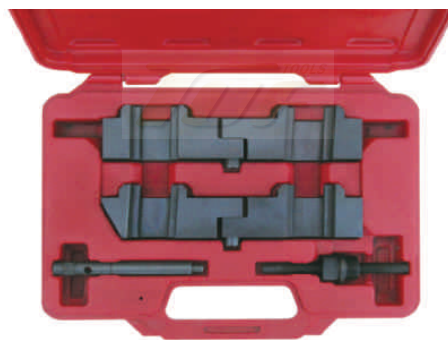
**3505****Twin Vanos Kit**

BMW雙可變氣門正時工具組

The kit which has been introduced to allow the twin vanos (variable valve control) system as fitted to M42, M44, M50, M52 engines to be set and adjusted.

This kit should be used in conjunction with the 3507 kit (refer to BMW engine chart to identify your engine type.)

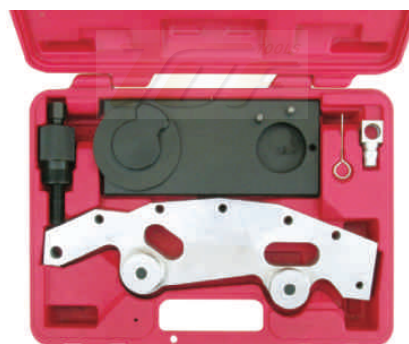
**3509****Diesel Engine Timing Tool Kit**

綜合型柴油正時工具組

- * Installation and removal of the camshaft and hydraulic chain tensioner.
- * Checking and adjustment of camshaft timing.
- * Easily accessible operating instructions including cross reference to original part numbers.
- * Suitable for BMW diesel engines M41, M51, M47TU, M47TU/T2, M57/TU/T2:2.01/3.01year 1988-2008.

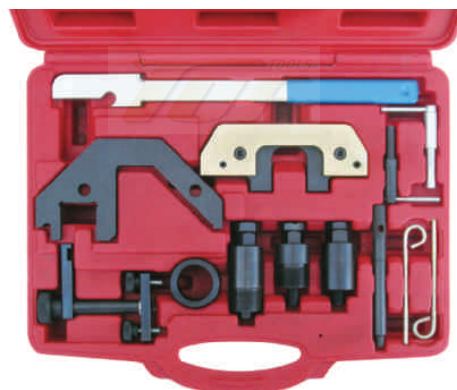
**3510****Diesel Engine Timing Tool Kit**

BMW, LAND ROVER柴油正時工具組

- * The kit has been designed specifically for the most popular BMW diesel engine ranges.
- * Primarily designed to fit the M47 engines.
- * For the TD4 and TD6 engines found in FREELANDER and the RANGE ROVER.
- * Suitable for 118D, 120D, 318D, 320D, 325D, 330D, 520D, 525D, 530D(2000-2010), FREE LANDER TD4, RANGE ROVER TD6 engine codes 204D3, TD4, 306DI, TD6(2000-2006).





4006 **VW & Audi Engine Timing Tool Master Kit**
VW, Audi綜合正時工具組

- * This kit is required for petrol and diesel engine service including timing belt replacement on recent models and also 1.9D models from 1976.
- * Suitable for Audi: A4, A6, A48, A11(97-04), VW: PASSAT (98-04)
- * Engines codes: AFB, AKE, AKN, AYM, BAU, BCZ, BDG, BDH, BFC.



4007 **VW & Audi Engine Timing Master Kit**
VW, Audi正時工具組 (13pcs)

Originally specified for pre-2003 petrol and diesel vehicles the kit is still relevant to many of the later SKODA, SEAT, VOLKSWAGEN, Audi vehicles.



4008 **Camshaft Locking Bar**
Audi正時工具 (V6)

- * A camshaft locking bar used to set the cams on the older pre-2000 V6 2 valve per cylinder petrol engines. Used to lock the camshaft in relation to one another.
- * Suitable for Audi 80, A4, A6 2.6, 2.8 V6 2 valves, per cylinder engines (1991-2000).



4010 **Camshaft Locking Bar**
VW, Audi正時工具 (V6)

- * A camshaft locking bar used to set the camshaft on the V6 5 valve per cylinder petrol engines. Used to lock the camshaft in relation to one another.
- * Suitable for A4, A6, A8, A11 ROAD, RS4, S4 2.4, 2.7, 2.8. 5 valve SOHC V6 engines (1997-2008).



4009 **Camshaft Locking Bar**
VW, Audi正時工具 (V8)

- * To hold the camshafts at TDC position while replacing the timing belt.
- * Suitable for VW, Audi with 40v V8, Audi A6 and A8 engines (8/1999-2006).

4011**VW, Audi Engine Timing Tool Kit (2.0 TFSI, FSI)**
VW, Audi 正時工具組 (2.0 TFSI, FSI)

- * With camshaft tools, chain tensioner retainer, locking pins and tensioner bolt.
- * For 2.0 FSI petrol engines since 2003-2010.
- * Suitable for Audi A3 2.0 FSI and FSI SOHC engine codes: AWA, BHD, BMB VW GOLF 2.0 FSI and 2.0 FSI SOHC and TOURAN 2.0 FSI SOHC engine codes: AWA, AXW.

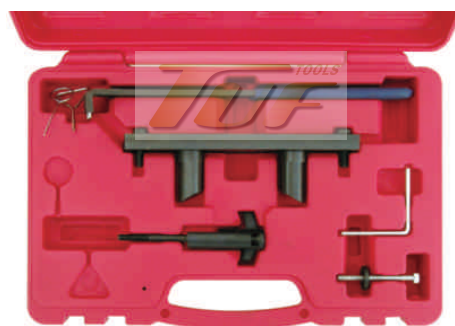
**4012****VW, Audi Turbo Locking Kit (1.6FSI, 1.8)**
VW, Audi 正時工具組 (1.6FSI, 1.8)

- * Timing tools for VAG 1.8 TURBO & 1.6 FSI chain driven engines.
- * Suitable for Audi / VOLKSWAGEN / SEAT / SKODA / 1.6FSI (2003-2009) / 1.8 TURBO (1996-2010).

**4013****VW, Audi Engine Timing Tool Kit (2.5 TDI)**
VW, Audi 正時工具組 (2.5 TDI)

- Suitable for:
- * Audi: A4, A6, A8, A11 ROAD (97-08), VW: PASSTA (98-05)
 - * Engines codes: AFB, AKE, AKN, AYM, BAU, BCZ, BDG, BDH, BFC.

**4014****VW, Audi Petrol Engine Locking Kit (1.2)**
VW, Audi 正時工具組 (1.2)

- * Suitable for VW group 1.2 single (6V) and twin camshaft (12V) 3 cylinder petrol engines (02-) in SEAT, LBIZA / CORDOBA, SKODA, FABIA, VW, POLO (2002-2010).
- * Engines codes: AWY, AZQ, BME, BZG.

**4015****Camshaft Locking Tool (VAG)**
正時工具 (VAG)

- * Easy to use for locking camshaft pulleys when changing cam belt.
- * Suitable for 1.4 and 1.6 16V twin camshaft engines, VW: LUPO 99-, POLO 95-, CADDY 96-, CLASSIC POLO, VARIANT 96-, BEETLE 1.4L 99-, GOLF 1.4L, 1.6L 98- and BORA 1.4l, 1.6L 99-.





4016 Camshaft Chain Tensioner Adjuster (VAG)
正時鏈條調整器

- * Used to retain camshaft chain adjuster.
- * Suitable for VW & Audi 4, 6 (2.7L & 2.8L) and 8 cylinder engines containing 5 valves per cylinder.

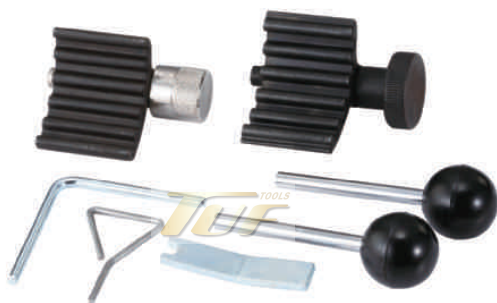

4002 Diesel Engine Timing Tool Kit (VAG)
柴油車正時工具組 (VAG)

- * Suitable for VAG 1.9, 2.0 Litre TDI / PD /DOHC engines fitted to Audi A4, A6 SKODA, OCTAVIA II and VOLKSWAGEN GOLF / GOLF PLUS / JETTA and TOURAN models.



4017 Audi Camshaft Alignment Tool Kit (V6)
Audi正時工具組 (V6)

- * Holding and alignment fixture align and hold camshaft.
- * Suitable for Audi A4, A6, A8 3.0 V6 (2001-2010).

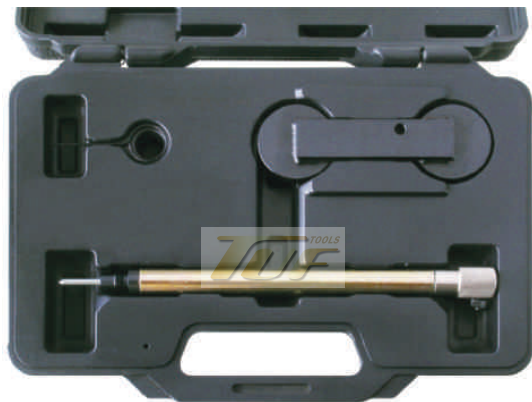

4019 VW Petrol Engine Locking Tool Kit (1.4, 1.6FSI)
VW正時工具組 (1.4, 1.6 FSI)

- * Suitable for VW group 1.4 /1.6 TFSI, FSI engines (2006-2009).

4018**Audi Camshaft Sprocket Adjusting Tool (V6)**

Audi凸輪軸調整工具 (V6)

- * Special groove nut socket to turn the camshaft adjuster into position.
- * Camshaft adjusting socket used to adjust variable valve timing on the exhaust side camshaft to basic position.
- * Suitable for Audi 3.0L V6 (2001-2010).

**4020****Camshaft Setting Tool (1.9 TDI)**

VW正時工具組 (1.9 TDI)

- * Suitable for VW POLO, GOLF, BORA, BEETLE, CADDY (1997-2005), 1.9TDI.

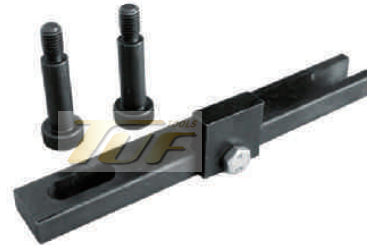
**4021****VW Diesel Water Pump Tool Kit (2.5)**

VW水泵浦工具組 (2.5)

This set allows the crankshaft rotation on TDC-position and the crankshaft counter hold, during the loosening of the crankshaft center screw or of the water pump toothed wheel fastening screw. It is also suitable for removal or extraction of the water pump toothed wheel and water pump itself.

For VW T5, TOUAREG 2.5L 5-cylinder TDI engines(2002-2010).

**1601****RENAULT Timing Tool Kit**

雷諾綜合正時工具組

- * Suitable for RENAULT 5, 9, 11, 18, 21, 25 / AVENTINE / CLIO I, II, III / ESPACE / EXPRESS / KANGCO / LAGUNA I, II / MASTER / MEGANE / SCENIC / MODUS / SAFRANE / TRAFIC. 1980 onwards.

**1602****RENAULT Timing Tool Kit**

雷諾正時工具組 (5pcs)

- * This timing tool kit of three specific components enables the timing position to be held on K4J, K4M & F4P, F4R twin cam 16V engines.
- * This new camshaft pulley setting tool holds two pulleys in place whilst changing the cam belt (1998-2010).
- * This tool is bolted to the centre of the cams using the existing bolts.





1603 OPEL, VAUXHALL Engine Timing Kit
OPEL, VAUXHALL 正時工具組 (26pcs)

- * A comprehensive 26pcs kit of engine timing locking tools for camshaft, crankshaft and flywheel.
- * Suitable for COVERS, CITROEN, FIAT, Ford, OPEL, PEUGEOT, RENAULT, ROVER, VAUXHALL, VOLKSWAGEN.



1604 OPEL Engine Timing Tool Kit
OPEL 正時工具組

- * Retains position of coolant pump sprocket during replacement of pump, maintaining engine timing.
- * Suitable for ASTRA VECTRA VX220 ZAFIRA & SIGNUM (2000-2004).
- * Codes: K9K, G9T, G9U.

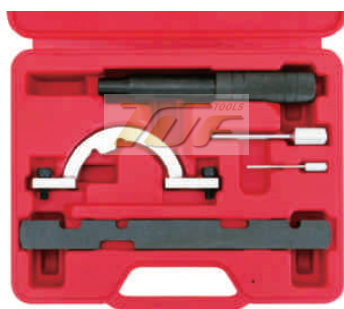

1605 VAUXHALL, OPEL Setting & Locking Kit
VAUXHALL, OPEL 正時工具組 (1.0, 1.2, 1.4)

- * Includes all the locking tools to time the chain on 1.0 / 1.2 / 1.4 petrol engines.
- * Codes: X10XE, Z10XE, XEP, Z12XE, XEP, Z14XEL, XEP (1993-2010).



1606 Diesel Engine Locking Kit
OPEL 正時工具組 (柴油車)

- * Primarily assembled to fit the Z coded 1.3 / 1.7 / 1.9 diesel engines from 2003 onwards. This kit also contains components to suit other late model diesel engines.
- * Suitable for AGILA B, ASTRA H, CORSA C, COMBO C, INSIGNIA, MERIVA A, TIGRA B, VECTRA C, ZAFIRA, B1.3, 1.7, 1.9, 2.0, also use on FIAT, SAAB.
- * Diesel engine codes: Z13DT, DTH, DTJ, D13A, Z17D, DTJ, DTR, Z19DT, DTH, DTR, DTJ, DTL, LBS, A20DTC, LBX, A20DTJ, LBX, A20DDTC (2003-2010).

1607**OPEL, GM Engine Timing Tool Kit**

OPEL, GM正時工具組

Suitable for VAUXHALL/OPEL, VECTRA 2.0D TURBO, SINTRA 2.2D TURBO, ZAFIRA 2.0D TURBO, FRONTERA-B 2.2D TURBO, SAAB 9-3 2.2D TURBO (1997-2006).

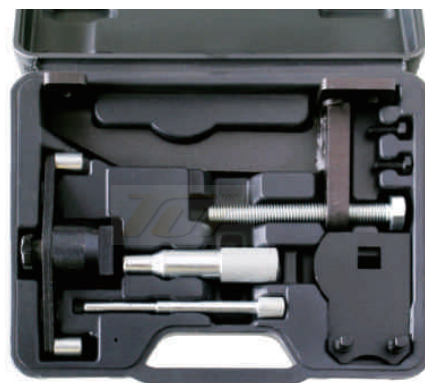
**1608****Engine Timing Kit (Diesel 2.5)**

正時工具組 (柴油車2.5)

* This timing tool kit includes: flywheel timing tool, crankshaft holding tool, crankshaft alignment tool, timing chain compressor, injection pump shaft lever, shaft puller timing pins for 2.5 TD5 engines.

* Suitable for OPEL, LAND ROVER, BMW (1994-2003).

**1609****FIAT Engine Timing Tool Kit**

FIAT正時工具組

* Suitable for petrol engines: FIAT BRAVA, BRAVO, BARCETTA, CARGO, COUPE, MAREA, PALIO WEEKEND, PUNTO, MULTIPLA, STILO, IDEA DOBLO, twin cam engines 1.2/1.4/1.6/1.8 16V.

* Suitable for diesel engines: FIAT BRAVA, BRAVO, MAREA/WEEKEND, PALIO, PUNTO, MULTIPLA, DOBLO, ULYSSE, DUCATO, STILI JTD diesel engines 1.9D/TD, 1.9JTD, 2.4TD/JTD.

**1610****FIAT Petrol Engine Locking Kit (1.6 16V)**

FIAT正時工具組 (1.6 16V)

* Suitable for BRAVA/BRAVO, MAREA/WEEKEND STILO, MULTIPLA & PALIO WEEKEND (1995-2010).

* Codes: 178B3.000, 182A4.00, 182A6.000 & 182B6.000.

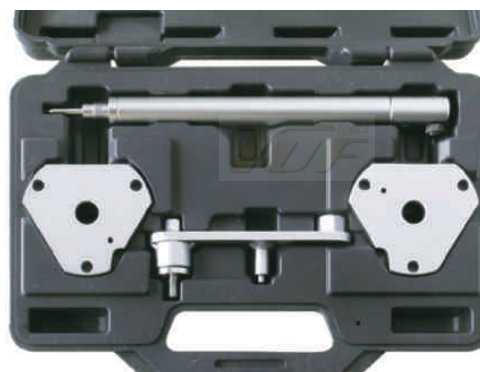



1611 **CITROEN, PEUGEOT Master Engine Timing Tool Kit**
CITROEN, PEUGEOT正時工具組

- * The most recent cars with either HPI (petrol) or HDI (diesel) engines.
- * CITROEN: AX, BX, ZX, XM, VISA, SAXO, XSARA, XANTIA SYNERGIE / EVASION, BERLINGO, JUMPY, C15, C25, PICASSO, C5.
- * PEUGEOT: 106, 205, 305, 306, 307, 309, 405, 406, 605, 607, 806, 807, EXPERT, PARTNER, BOXER.

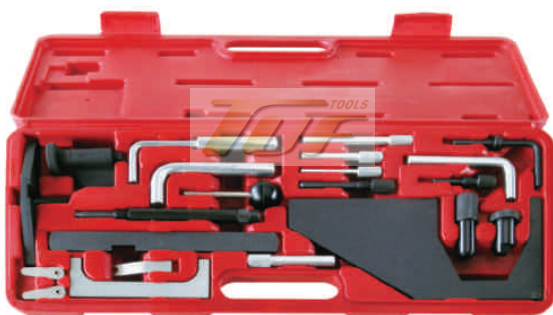

1612 **Ford, MAZDA Master Engine Timing Tool Kit**
Ford, MAZDA正時工具組

- * Suitable for ESCORT, FIESTA, FOCUS, ORION, PUMA, SIERRA, TRANSIT, MONDEO (pre 2007 models).



1613 **Engine Timing Tool Kit (TDDi, TDCi)**
Ford正時工具組 (TDDi, TDCi)

- * Suitable for Ford 1.8 TDDi /TDCi from 2000 to 2006 including FIESTA, FOCUS, CAMAX, TOURNEO, TRANSIT with chain driven engines.



1177 **Ford, MAZDA Timing Tool Kit (5pcs)**
Ford, MAZDA正時工具組 (5pcs)

- * The plate is used to fix camshaft.
- * The 3 bolts are designed to fix crankshaft.
- * Suitable for Ford/MAZDA petrol and diesel engines, VOLVO 1.8, 2.0 petrol engine.

1434**Camshaft/Crankshaft Alignment Tool Kit**
VOLVO正時工具組

- * Special made for alignment of the cam and crankshafts.
- * Allows correctly installation of the camshafts with the cam cover.
- * Suitable for VOLVO models 850, 960, S40, S70 and S90.

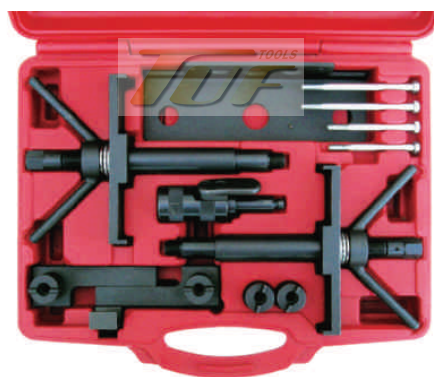
**1127****Camshaft Locking Tool**
雙凸正時固定工具 (通用型)

The locking is for toothed pulleys spaced between approximately 0-60mm apart.

- * Universal
- * Adjustable
- * Twin cam and diesel engines

To ensure the pulleys driver not lose the relationship to the crankshaft during repairing or changing the timing belt.

**1079****Twin Camshaft Locking & Setting Kit**
綜合型正時工具組 (19pcs)

- * It provides different camshaft locking pins that can cover specific crankshaft and flywheel locking applications.
- * Allows the service easier and reduce the risk of incorrect valve timing from taking place.
- * Suitable for Ford, HONDA, LAND ROVER, ROVER, VAUXHALL, OPEL, PEUGEOT, VW, ISUZU.

**1614****Engine Timing Tensioner Kit**
正時惰輪調整組

- * A comprehensive range of tension lever and wrenches required for changing the cam belt on most popular petrol and diesel engines.
- * Suitable for ALFA ROMEO, FIAT, CITROEN, PEUGEOT, Audi, RENAULT, VOLKSWAGEN, SKODA.

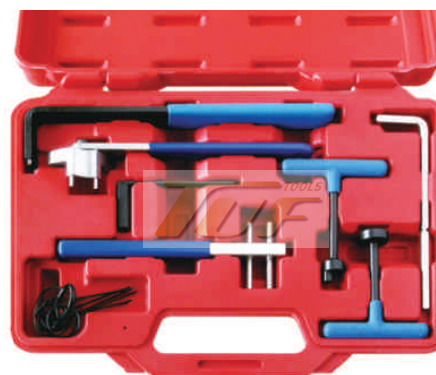
**1615****Multi Purpose Tensioner**
VW, Audi惰輪調整扳手

Multi-fit tensioner wrench with an adjustable head position. Used across the VAG range.





1616

VOLVO Idler Wrench

VOLVO惰輪調整扳手

- ★ * TX-Star: T50, T60
- ⊙ * Double-Hex: 14mm
- * Length: 420mm



1427

Timing Belt Offset Bearing Adjuster Tool

三菱皮帶惰輪調整器

- * Required when setting up timing belts on all MITSUBISHI turbo engines.
- * 1/4" drive.



1110

Balancer Puller & Installer Kit

正時皮帶盤拆裝組

- * A professional tool kit for balancer replacement.
- * Built-in bearing makes balancer replacing job easy and damage-free.
- * 4-slot puller plate plus 9 threaded adapters to fit on balancers on most engines.

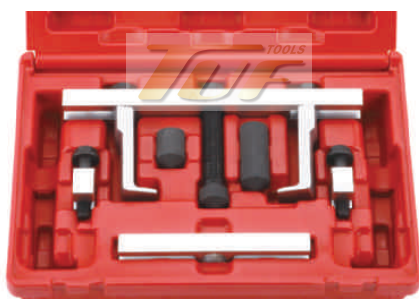

1409

Changeable Two Jaws Pulley Remover Kit

二爪式皮帶盤拔卸組

- * Suitable for using when the space limited.
- * To change the parts easily for fitting the different cars.
- * Jaw length: 72/95mm.
- * Jaw depth: 18mm; width: 4.4mm.



4003

Camshaft Sprocket Puller Kit

VW, Audi凸輪軸皮帶盤拆卸組

This camshaft sprocket pulley puller has been specifically designed for use on Audi, SKODA and VOLKSWAGEN V6, V8 and 4 cylinder engines with 5 or 6 spoke camshaft pulleys.

4022**VW, Audi Camshaft Pulley Remover**
VW, Audi凸輪軸皮帶盤拆卸器 (TDI)

- * Special design for removing the camshaft pulley on diesel engine TD, TDI etc...
- * Suitable for VW, Audi, SKODA, SEAT.

**1058****Universal Camshaft Sprocket Puller Kit**
通用型凸輪軸皮帶盤拆卸組

- * Hold the sprocket and undo the retaining bolt or nut and remove.
- * This tool enables the removal of the camshaft sprocket on a wide range of vehicles.
- * Suitable: 45-70mm.

**1436****Crank Pulley Removal Tool Kit (Manual Type)**
皮帶盤支撐拆裝組

- * Suitable for mainly used in vehicles with vertically placed engines. Especially in TOYOTA JZ type/ 1G type / NISSAN RB type / VG type / VQ type (Excluding diesel types).
- * Exclusive to the V-ribbed belt.
- * Pulley outer diameter: $\phi 90-180$.
- * Where a service tap is included: fits with M6, M8.

**1061****Camshaft Pulley Remover / Installer**
固定式皮帶盤拆裝器

- * Designed to hold the camshaft pulley stationary while loosening and tightening the center shaft bolt.
- * Using the centered screw rod to uproot the pulley.
- * Locking screw: M8, M10.
- * Fixed distance: 54-120mm.

**1703****Thin Type Two Jaws Bearing Remover**
二爪薄型拔卸器

- * Special design for removing the bearing in narrow space.
- * Working depth: 93mm
- * Jaws thickness: 1.5mm
- * Applicable bearing dimension: $\phi 30-90$ mm





4023 Water Pump Pulley Holding Wrench
VW, Audi 水泵浦皮帶盤支撐扳手

- * Safe locking of the water-pump pulley for loosening of stubborn bolts.
- * Application: for locking of deep-drawn water-pump pullers on VW and Audi engines with air conditioning.



4024 Reaction Wrench
泵浦皮帶盤支撐扳手

- * For locking the pulley on the servo-pump on VW POLO, GOLF, PASSAT Audi 80/A4.
- * The 1/2" drive in the tools handle enables an extension of the tool by a ratchet.
- * Easy loosening of stubborn bolts on the water-pump pulley.
- * L: 250mm



1701 HONDA, ACURA Crankshaft Pulley Holding Tool
HONDA正時皮帶盤支撐器

- * Tool allows the technician to hold the crankshaft damper when tightening or loosening the crankshaft bolt.
- * Works on the following HONDA and ACURA engines.
- * 1/2" drive.



1426 Universal Camshaft Holding Lever
通用型皮帶盤支撐扳手組

- * A versatile lever tool for holding the camshaft sprocket.
- * Supplied with a variety of pins to allow fitment to many different sprocket profiles.



1069 Belt Tool Kit (5pcs)
皮帶拆裝輔助器 (5pcs)

- * Special designed for installing and removing the new belt onto the pulley.
- * Suitable for engines with elastic ribbed belts such as ALFA ROMEO, BMW, CHRYSLER, FIAT, Ford, Mercedes, PSA, SEAT, SKODA, smart, VOLVO, VW, Audi, MAZDA, LANCIA, CITROEN.



1411**Belt Installing Tool Kit (3pcs)**

皮帶安裝輔助器 (3pcs)

- * Special designed for installing the new belt onto the pulley.
- * Suitable for Ford, MAZDA, VOLVO, BMW, CHRYSLER, CITROEN, FIAT, LANCIA.

**1702****Pulley Spinning Tool**

皮帶盤調整扳手

- * Special tool for forged pulley.
- * For turning and spinning off the crankshaft, camshaft.
- * Length: 330mm
- * Suitable for Japanese vehicles, Mercedes Benz, BMW, Ford, OPEL, PEUGEOT, RENAULT, ROVER, VOLVO, VW, Audi.
- * Warning: This tool is NOT for "counter-holding" wrench for shaft.

**1068****Power Steering Pump Pulley Kit**

動力方向盤拆裝組

- * THOMPASON and Ford C111, C2 power steering pumps found on Ford, GM & CHRYSLER vehicles.
- * A disconnect tool to release the power steering line from pump on 1989-current GM pickups 1/2T, 3/4T & 1T.

**1437****Universal Pin Spanner Set**

調整型二點轉動扳手組

- * Made of special steel to adjust or remove the twin-hole nuts.
- * Replaceable pins and central adjustable nut for any size you need.
- * Pins size: 2.5, 3, 4, 5, 6, 7, 8, 9mm, each size with 2 purchase.
- * Operation range: 20-100mm.

**1452****Pin-type Face Spanner Set**

二點式替換調整扳手組

- * For twin-hole nuts, with inter-changeable pins.
- * Nut size:
 - 1.5mm / 2.5mm, 2.0mm / 3.0mm
 - 3.0mm / 5.0mm, 4.0mm / 6.0mm
 - 5.0mm / 7.0mm, 6.0mm / 8.0mm
 - 8.0mm / 10.0mm, 10.0mm / 12.0mm





3511 **BMW Fly Wheel Holder Kit**
BMW飛輪盤支撐扳手組

- * When replacing timing chain, this tool can block flywheel.
- * It helps to release and tighten down central bolts on vibration damper.
- * BMW engine repair tool.
- * Suitable for BMW (M47T2 / M47TU / M57T2 / M57TU / M67 / N45 / N45T / N46 / N46T / N51 / N52 / N53 / N54 / W17)

1065A **Radiator Pressure Tester & Vacuum-Type Cooling System (27pcs)** 水箱壓力試驗器 (27pcs)

- * Specification for radiator test caps
- * Radiator cap suitable:
 - 0-Thermometer
 - 1-Pressure testing pump with gauge
 - 2A-Connector R123/R124 (black color)
 - 2B-Connector R123/R125 (blue color)
 - 3-Mercedes Benz (W123, W126, W124, W201), GM (BUICK), Jeep
 - 4-PEUGEOT, SUBARU, CHRYSLER, ACURA, GM (NOVA, SPECTRUM, SPRINT), MITSUBISHI, NISSAN, MAZDA, TOYOTA, INFINITI, GEO, SUZUKI, ISUZU, Mercedes Benz
 - 5-HONDA, TOYOTA, SUZUKI, MITSUBISHI, CHRYSLER, ACURA, LEXUS
 - 6-Mercedes Benz (ML-class, W163, W164), GM (ACHIVA, SKYLARK, GRAND AM-1992-2002)
 - 7-VOLVO, SAAB, STERLING, CITROEN, RENAULT, FIAT, ALFA, Jeep, MINI
 - 8-VW (VENTO, T4, PASSA-1996, GOLF, BEETLE, SHARAN)
 - 9-Audi (A4, A5, A6), BMW 345, VW (PASSA-1997-2002), PORSCHE (CAVENNE)
 - 10-BMW (E46, E36, E34, E39, E38, E32, E90)
 - 11-Audi, VW
 - 12-Ford (MONDEO), INTERNATIONAL, LAND ROVER, OPEL, SSANGYONG MOTOR
 - 13-Mercedes Benz (C-class, E-class, W140, W220, W124, W210, W211, W215, W216, W221, R230)
 - 14-Ford (Mondeo), FOCUS, C-MAX03
 - 15-MAZDA (M3)
 - 16-Mercedes Benz A-class (W168)
 - 17-BMW E60, E63, E64, E65
 - 18-VW SHARAN 1.8T2.8
 - 19-TOYOTA-RAV4, PREVIA
 - 20-SAAB
 - 21-Ford, JAGUAR, OPEL, LAND ROVER, BUICK, Mercedes Benz (M-class)
 - H-Handle
 - V-Vacuum purge tool (3pcs)



1065 **Radiator Pressure Tester & Vacuum-Type Cooling System (26pcs)** 水箱壓力試驗器 (26pcs)

The same description as 1065A except for 21

1064A**Universal Radiator Pressure Tester Kit (19pcs)
水箱壓力試驗器 (19pcs)**

* Radiator cap suitable:

- 0-Thermometer
- 1-Pressure testing pump with gauge
- 2A-Connector R123/R124 (black color)
- 2B-Connector R123/R125 (blue color)
- 3-Mercedes Benz (W123, W126, W124, W201), GM (BUICK), Jeep
- 4-PEUGEOT, SUBARU, CHRYSLER, ACURA, GM (NOVA, SPECTRUM, SPRINT), MITSUBISHI, NISSAN, MAZDA, TOYOTA, INFINITI, GEO, SUZUKI, ISUZU, Mercedes Benz
- 5-HONDA, TOYOTA, SUZUKI, MITSUBISHI, CHRYSLER, ACURA, LEXUS
- 6-Mercedes Benz (ML-class, W163, W164), GM (ACHIVA, SKYLARK, GRAMD AM-1992-2002)
- 7-VOLVO, SAAB, STERLING, CITROEN RENAULT, FIAT, ALFA, Jeep, MINI
- 8-VW (VENTO, T4, PASSA-1996, GOLF, BEETLE, SHARAN)
- 9-Audi (A4, A5, A6), BMW 345, VW (PASSA-1997-2002), PORSCHE (CAVENNE)
- 10-BMW (E46, E36, E34, E39, E38, E32, E90)
- 11-Audi, VW
- 12-Ford (MONDEO), INTERNATIONAL, LAND ROVER, OPEL, SSANGYONG MOTOR
- 13-Mercedes Benz (C-class, E-class, W140, W220, W124, W210, W211, W215, W216, W221, R230)
- 14-Ford (Mondeo), FOCUS, C-MAX03
- 15-MAZDA (M3)
- 19-TOYOTA-RAV4, PREVIA
- H-Handle

**1138****Vacuum-Type Cooling System Refill Kit (3pcs)
真空式水箱水更換組 (3pcs)**

Please empty water of radiator. Choose a suitable rubber bush, and place it between cooling system adaptor and radiator tightly. Connect cooling system adaptor to vacuum pump and connect shop air to air connector. Then turn on the switch. Allow air pressure to reach a vacuum level approximately between 20-25 inHG (50-60cmHG) of mercury. Please turn off the switch, and take off the vacuum pump.

1070**CO₂ Checking in Radiator with CO₂ Test Liquid
CO₂水箱測試器**

- * If exhaust gasses presents in cooling system, the color of test liquid turns from blue to green or yellow when the steam mixes with CO₂ detector liquid in detector.
- * If the detector liquid still in blue during test operating, it means the gasket keeps in good condition.



1404 1/2" Dr. Alternator Insert Bit Socket Kit (13pcs)
發電機皮帶盤拆裝組 (13pcs)

- * 1pc--M10 Spline Bit Socket with 33T Nut: 110mm (L)
- * 1pc--T50 Tx-Star Bit Socket with 33T Nut: 110mm (L)
- * 2pcs--Spline Bit: M8, M10, 75mm (L)
- * 2pcs--Tx-Star Bit: T40, T50, 75mm (L)
- * 2pcs--Hex Bit: 8, 10mm, 75mm (L)
- * 2pcs--33T Alternator Nut with 17, 22mm Hex Tip
- * 1pc--22mm Hex Alternator Nut
- * 1pc--4 Points Alternator Nut with 17mm Hex Tip
- * 1pc--1/2" Dr. x 10mm Hex Bit Holder



1405 1/2" Dr. Alternator Insert Bit Socket Kit (18pcs)
發電機皮帶盤拆裝組 (18pcs)

- * 1pc--M10 Spline Bit Socket with 33T Nut: 110mm (L)
- * 1pc--M10 Spline Bit Socket with 31T Nut: 98mm (L)
- * 1pc--M10 Spline Bit, 14mm Hex Drive: 57mm (L)
- * 1pc--M10 Spline Bit Socket: 110mm (L)
- * 1pc--T50 Tx-Star Bit Socket with 33T Nut: 110mm (L)
- * 2pcs--Spline Bit: M8, M10, 75mm (L)
- * 2pcs--Tx-Star Bit: T40, T50, 75mm (L)
- * 2pcs--Hex Bit: 8, 10mm, 75mm (L)
- * 2pcs--33T Alternator Nut with 17, 22mm Hex Tip
- * 1pc--22mm Hex Alternator Nut
- * 2pcs--Hex Alternator Nut: 28x21mm, 28x19mm
- * 1pc--4 Points Alternator Nut with 17mm Hex Tip
- * 1pc--1/2" Dr. x 10mm Hex Bit Holder



1406 1/2" Dr. Alternator Insert Bit Socket Kit (22pcs)
發電機皮帶盤拆裝組 (22pcs)

- * 1pc--M10 Spline Bit Socket with 33T Nut: 110mm (L)
- * 1pc--M10 Spline Bit Socket with 31T Nut: 98mm (L)
- * 1pc--M10 Spline Bit, 14mm Hex Drive: 57mm (L)
- * 1pc--M10 Spline Bit Socket: 110mm (L)
- * 1pc--T50 Tx-Star Bit Socket with 33T Nut: 110mm (L)
- * 2pcs--Spline Bit: M8, M10, 75mm (L)
- * 2pcs--Tx-Star Bit: T40, T50, 75mm (L)
- * 2pcs--Hex Bit: 8, 10mm, 75mm (L)
- * 3pcs--33T Alternator Nut with 15, 17, 22mm Hex Tip
- * 2pc--Hex Alternator Nut: 17, 22mm
- * 3pcs--Hex Alternator Nut: 28x22mm, 28x21mm, 28x19mm
- * 1pc--4 Points Alternator Nut with 17mm Hex Tip
- * 1pc--3 Points Alternator Nut with 38mm Hex Tip
- * 1pc--1/2" Dr. x 10mm Hex Bit Holder



5115 Alternator Nut
發電機皮帶盤拆卸器

- * Size: 33T x 17mm Hex

1438 1/2" Dr. Alternator Insert Bit Socket Kit (30pcs) 發電機皮帶盤拆裝組 (30pcs)

- * 1pc--M10 Spline Bit Socket: 120mm (L)
- * 1pc--M10 Spline Bit Socket: 140mm (L)
- * 1pc--M10 Spline Bit, 14mm Hex Drive: 57mm (L)
- * 1pc--3/8" Dr., M10 Spline Bit Socket with 31T Nut: 90mm (L)
- * 1pc--8mm Hex Bit Socket: 120mm (L)
- * 1pc--T50 Tx-Star Bit Socket: 120mm (L)
- * 2pcs--Spline Bit: M8, M10, 75mm (L)
- * 2pcs--Tx-Star Bit: T40, T50, 75mm (L)
- * 2pcs--Hex Bit: 8, 10mm, 75mm (L)
- * 2pcs--10mm Hex Drive x H10 Bit: 50, 70mm (L)
- * 1pc--33T Alternator Nut with 15mm Hex Tip: big round
- * 3pcs--33T Alternator Nut with 15, 17, 22mm Hex Tip
- * 1pc--17mm Hex Alternator Nut-Inner size: 14mm
- * 1pc--1/4" Dr., 10mm Hex Socket
- * 2pc--Hex Alternator Nut: 17, 22mm
- * 5pcs--Hex Alternator Nut: 28x22mm, 28x21mm, 28x19mm, 17x19mm, 17x21mm
- * 1pc--4 Points Alternator Nut with 17mm Hex Tip
- * 1pc--3 Points Alternator Nut with 38mm Hex Tip
- * 1pc--1/2" Dr. x 10mm Hex Bit Holder



1316 Diesel Injector Nozzle Extractor Kit 柴油噴油嘴拆卸器 (賓士)

- * Suitable for Mercedes A&B CDI engine OM 611, 612, 613.



1319 Injector Nozzle Puller Kit (Slide Hammer Style) 柴油噴油嘴拆卸器 (滑錘式)

- * For removing adapted tight common rail injectors without disassembling cylinder head.
- * Use for Mercedes-Benz CD engines 611, 612, 613.
- * Injection puller with impact hammer, injection nozzles that do not fit very tightly can be pulled out without needing to take them apart or remove the cylinder block.



1317 Diesel Injector Nozzle Extractor Kit BMW柴油噴油嘴拆卸器

- * Complete set for removing BMW common rail injectors, specially designed for M57 and M57TU engines. This kit allows the removal of tightly fit injectors nozzles without removing the cylinder head.
- * Suitable for BMW M57 & M57TU engine.





1318 Diesel Injector Nozzle Extractor Kit
柴油噴油嘴拆卸器 (PSA)

* Suitable for PSA 2,0 (110, 135 HP) HDI engines e.g. PEUGEOT, CITROEN etc. (engine code DW10)



1320 Cleaning Tool for Injection Nozzle Seat Set
VW, Audi噴油嘴座清除器

* Suitable for 2.0 TDI engine from VAG group.
* To clean the contact surface between the injector and engine head during the replacement.
* Includes cutter holder to make straight and correct for attaching when cleaning.
* Insert the extension bar for deep hole cleaning.



1321 Diesel Injector Seat Cleaner Set (6pcs)
柴油噴油嘴座清除器

* 15x19mm flat reamer -- universal applications
* 17x17mm angled reamer -- Mercedes-Benz CDI
* 17x17mm flat reamer -- DELPHI / BOSCH injectors (BMW / PSA / RENAULT / Ford)
* 17x19mm flat reamer -- BOSCH injectors (Mercedes CRD)
* 17x21mm angled reamer -- FIAT / IVECO
* Pilot post



1322 Injector Cap Removal Socket Set (4pcs)
柴油噴油嘴套筒組 (4pcs)

* Removes the top cap and connectors on diesel fuel injectors prior to injector removal.
* Deep socket and wide cut-out configuration are essential for this application.
* Fits the most popular injectors found in modern vehicles.
* 1/2" Dr. socket can use for SIEMENS & BOSCH
* Size: 25, 27, 29, 30mm
* Suitable for PEUGEOT and CITROEN with 2.0 engines (110/135HP) HDI engine.



1323 BMW Diesel Injection Pump Remover & Sprocket Retainer BMW柴油噴射泵浦拆卸器

* Removes the diesel pump and sprocket in-situ so that the sprockets/timing chain configuration remains undisturbed, minimizing the level of engine disassembly. For engine timing use setting.
* Suitable for BMW, E46 318D/TD, 320D/TD compact, 330D, E60/E61 525D, 530D, 535D, E38 730D, E53 X5 3.0D engines M47/M47TU/M57/M57TU.

1324**LAND ROVER Diesel Injection Pump Remove & Sprocket Retainer LAND ROVER柴油噴射泵浦拆卸器**

- * Removes the diesel pump and sprocket in-situ so that the sprockets/timing chain configuration remains undisturbed, minimizing the level of engine disassembly. For engine timing use setting.
- * Suitable for LAND ROVER; FREELANDER (TD4), ROVER; 75 2.0D (M47R engine)

**1325****Fuel Injection Pump Adapter Timing Tool Kit 噴射泵浦校正器**

- * BOSCH diesel injection pump timing indicator tools.
 - * Dial indicator and holder.
- Tools are used for the accurate setting of the BOSCH diesel fuel injection pump timing. The holder screws into the back of the injection pump, giving a dial indicator reading necessary for setting the correct pump timing. This set comes complete with the correct tools for the job.
- Suitable for BOSCH VE fuel pump, diesel pumps, indicator holder for both size shanks, also works with 1981-1986 VOLVO 6 cyl 2.4L diesels, 1989-1994 DODGE 6 cyl 5.9L diesels.

**4025****Injectors Pump Extractor Remove Kit VW, Audi綜合噴油嘴拆卸組**

- * Use "U" sleeve or two jaws hook to fix the injector and then pull out with slide hammer.
- * Special two jaws design to fix the injector and pull out with slide hammer
- * Suitable for VW, Audi TDI/FSI, SEAT, SKODA.

**4026****VW, Audi Diesel Injector Removeer VW, Audi柴油噴油嘴拆卸器**

- * Special design to remove the seized injector from VAG TDI engines.
- * Always cool down the engine before using the tool.
- * Suitable for VW, Audi TDI engine code: ALH/AHU/1Z.

**4027****VW, Audi Injector Removeer (TDI) VW, Audi柴油噴油嘴拆卸器 (TDI)**

- * Special two jaws design to fix the injector and pull out with slide hammer.
- * Suitable for VW, Audi TDI engine.





4028 VW, Audi Injector Remover (FSI)
VW, Audi噴油嘴拆卸器 (FSI)

- * Use "U" sleeve or two jaws hook to fix the injector and then pull out with slide hammer.
- * Suitable for VW, Audi FSI engine.



1327 Extra-Long Glow/Spark Plug Socket Set (with Clip)
預熱塞套筒組 (6pcs/附夾片)

- * 6pcs--3/8" Dr. x 158mm
- 8mm (Mercedes, VAUXHALL / OPEL, FIAT, LANCIA)
- 9mm (VAUXHALL / OPEL, FIAT)
- 10mm (Mercedes, VAG)
- 12mm (Mercedes, VAG, BMW, PEUGEOT, RENAULT)
- 14mm (RENAULT, CITROEN, PEUGEOT)
- 16mm (ALFA ROMEO, FIAT, Ford, MAZDA, CITROEN, PEUGEOT, HONDA, Mercedes, NISSAN, VAUXHALL, PORSCHE)



1328 Glow Plug Puller Kit (7pcs)
預熱塞拔取器 (7pcs)

- * Designed to pull out the broken head glow plug on the engine.
- * 5pcs outside holder jaw size: $\phi 2.7 \times 1$, $\phi 3.6 \times 1$, $\phi 5 \times 2$, $\phi 6 \times 1$.
- * 1pc inside holder jaw size: $\phi 5.5$.



1306 Damaged Glow Plug Removal Set
預熱塞孔修護器

- * Designed to remove damaged / broken glow plugs from cylinder heads.
- * Suitable for glow plugs with an M8x1mm and M10x1mm thread.



3008 Glow Plug Tool (CDI)
賓士預熱塞拆裝器

- * For unscrewing and disassembly of glow plugs in the cylinder head, especially for glow plugs that are stuck because of carbonization remains.
- * Cylinder does not need to be removed any more.
- * Fits all Mercedes 10mm glow plugs, engine codes 611-612-613 etc.

1329**Glow Plug Thread Repair Kit (33pcs)**
預熱塞孔螺牙修護組 (33pcs)

- * Fast and effective remedy for damage to cylinder head glow plug threads.
- * Tap size: M8x1.0, M10x1.0, M10x1.25, M12x1.0, M12x1.25, M14x1.25
- * Thread coil size: M8x1.0(I)-M10x1.0(E), M10x1.0(I)-M12x1.0(E), M10x1.25(I)-M12x1.25(E), M12x1.25(I)-M14x1.25(E)
- * 2pcs--thread coil driver

**1305****Flow Meter Common Rail Adaptor Kit**
柴油噴油測試器

The purpose of this instrument is to measure rapidly and effectively the amount of fuel that every injector returns to the deposit tank, so that you will know if any injector is damaged.

Features:

- * Direct measurement of return flow of the injector
- * Measurement of return flow using external flow meter
- * Possibility of simultaneous measurement of up to 6 injectors
- * Box for transportation and storage is included
- * Set included 24pcs injector adaptors for BOSCH, SIEMENS, DENSO and DELPHI injector

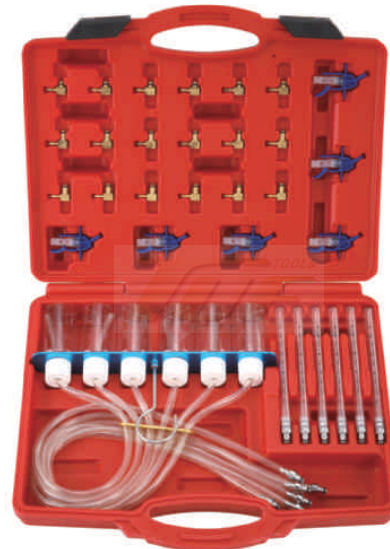
**1307****Diesel Engine Compression Tool Kit (37pcs)**
柴油汽缸壓力錶組 (37pcs)

- * As this kit but with the addition of it clamp-on injector adaptor set.
- * Large, 2-1/2", 70kg/cm²(1000psi) gauge with rubber bumper, straight and right angled quick connect fittings, an extensive range of glow plug, and injector adaptors enable this kit to cover the vast majority of car, van, truck and bus, agricultural and marine diesel engines.
- * Glow plug adaptor: wide range of ALFA, BMW, CHRYSLER, DAEWOO, FAIT, Ford, HYUNDAI, ISUZU, LAND ROVER, LDV, MAZDA, Mercedes, MITSUBISHI, NISSAN, OPEL, PSA, RENAULT, SAAB, SUZUKI, TOYOTA, VAG, VAUXHALL, VOLVO diesel engines.
- * Injector: M20, M22, M24 & Ford Stanadyne injector plus clamp-on injector.

**1312****Diesel Engine Compression Tool Kit**
柴油汽缸壓力錶組

- * Set includes clamp-on injector adaptor set.
- * Large, 2-1/2", 70kg/cm²(1000psi) gauge with rubber bumper, straight and right angled quick connect fittings, an extensive range of glow plug, and injector adaptors enable this kit to cover the vast majority of car, van, truck and bus, agricultural and marine diesel engines.
- * Glow plug adaptor: wide range of ALFA, BMW, CHRYSLER, DAEWOO, Ford, LAND ROVER, Mercedes, MITSUBISHI, NISSAN, PSA, RENAULT, SAAB, VAG, VAUXHALL, VOLVO diesel engines.
- * Injector: M20, M22, M24 & Ford Stanadyne injector plus clamp-on injector.





1066 Gasoline Engine Injecting Pressure Tester Kit
 汽油噴射壓力錶組 (全車種)

- * Large 3-1/2" gauge with dual readings of 0-145psi and 0-1000kpa.
- * All adaptors, gauges, and hose assemble feature a quick coupling system for speedy and efficient testing connection.
- * The uniquely designed relief valve relieves the pressure and the fuel safely. Also allows checking for sufficient fuel flow.
- * No need for wrenches or pipe dope.
- * The adaptor set tests fuel injection systems on vehicles on most makes and models: ACURA, HONDA, HYUNDAI, MAZDA, SUZUKI, TOYOTA, Audi, BMW, Mercedes, PUEGOT, PORSCHE, SAAB, VW, VOLVO.



1310 Fuel Injection Pressure Test Kit
 汽油噴射壓力錶組 (雙錶式)

- (Added Ting Valves Per Each Adaptors)
- * Large 3-1/2" gauge with dual readings of 0-145psi and 0-1000kpa. Also a low pressure 2-1/2" gauge for an accurate reading below 15 psi.
 - * All adaptors, gauges, and hose assembles feature a quick coupling system for speedy and efficient testing connection.
 - * The uniquely designed relief valve relieves the pressure and the fuel safely. Also allows checking for sufficient fuel flow.
 - * No need for wrenches or pipe dope.
 - * The adaptor set tests fuel injection systems on vehicles on most makes and models: ACURA, HONDA, HYUNDAI, MAZDA, SUZUKI, TOYOTA, Audi, BMW, Mercedes, PUEGOT, PORSCHE, SAAB, VW, VOLVO.

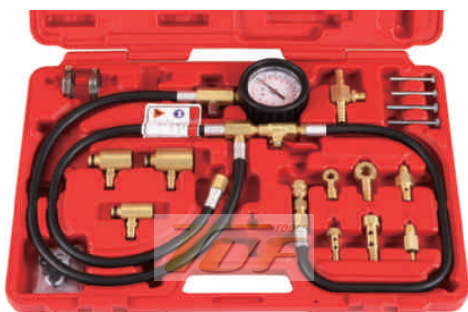

1309 Fuel Injection Test Kit
 汽油噴射壓力錶組 (日系車)

- * The fuel injection test kit checks fuel pressure and volume on most Asian system. Quickly diagnoses fuel related problems like hesitation, stumble, stall and lack of power caused by low fuel pressure, defective fuel pressure regulators and low fuel volume to the injectors plus much more.
- * Fitting seals are compatible with most popular cleaning solvents.
- * All fittings have quick connect Schrader valves for safety and ease of hookup to the gauge assembly.
- * For HYUNDAI, HONDA, MITSUBISHI, and other Asian automotive engines.

3512**BMW Oil Cooler Line Pliers****BMW變速箱油冷卻管拆卸鉗**

- * Designed to release hydraulic cooling lines connected to the transmissions.
- * Suitable for BMW E46/E53/E65/E66/E85 and BMW Mini R50/R53.

**1330****Fuel Line Pliers****汽油管接頭拆卸器**

- * For use on fuel filter connectors during replacement.
- * Prevents fuel leakage from damaged fuel connectors.
- * Suitable for Audi, GM, Mercedes, TOYOTA and VW.

**1414****Fuel Line Puller****汽油管拆卸器**

- * To remove the injector of high side adaptor of TOYOTA, NISSAN.
- * Special specification to meet type of adaptor, easy using.

**1428****Oil & Fuel Pipe Stopper****油管止油器**

- * Ideal for sealing metal brake pipes.
- * This stopper suitable for clamping and sealing metal flared pipes on braking systems, cooling system, fuel pipes etc.
- * Size range: 4-10mm

**1413****Pinch-Off Locking Hose Pliers****11"快速封管鉗**

- * Invaluable aid for brake repairs on cars.
- * Long rounded jaws with smooth section: instant pinch-off hoses without serration.
- * Milled tip and throat: allow firm gripping on small sections & pipes.
- * Length: 285mm
- * Jaw adjustment: 0-100mm

**1125****Pinch-Off Locking Hose Pliers****9-1/2"封管鉗**

- * Eliminates the draining of cooling system when installing thermostats and water pumps on pressurized cooling systems.
- * Swivel jaws for level clamping.
- * Positive clamping for tight seals on large radiator and other hoses.
- * Length: 9-1/2"





1315 **Hose Clamp Set (3pcs)**
封管鉗組 (3pcs)

- * Made of plastic. For clamping hoses, such as radiator hoses, heater hoses, fuel hoses, etc.
- * Up to $\phi 60\text{mm}$.



1086 **Brake and Fuel Hose Clamp**
小型封管鉗

- * Completely and positively seals reinforced brake or fuel lines with adjustable sliding locking ring.
- * Round jaws prevent hose from damage.
- * Length: 200mm
- * Capacity: 13mm



Flare Nut Wrench
加長單開口扳手

- * Used for TOYOTA, HONDA bolts of fuel filter cup.
- * Special design with cover for holding the nut completely and prevent slipping.
- 7204:** 3/8"x14mm, 94mm(L)
- 7204A:** 3/8"x17mm, 97mm(L)



1431 **Fuel Tank Sender Spanner Set (Adjustable)**
調整型汽油桶蓋拆裝器

- * Universal application of 24mm driver.
- * For removing and replacing the plastic retaining ring on the sender unit on fuel tanks.
- * Includes 3 series of extension
- * Range for: $\phi 75\text{-}160\text{mm}$, $\phi 80\text{-}122\text{mm}$, $\phi 110\text{-}170\text{mm}$.



1107 **Oil Filter Wrench Set (7pcs)**
碗式機油芯扳手組 (7pcs)

- Contents:
- * 65-14P, 68-14P, 76-14P, 80/82-15P, 86-16P, 100-15P.
 - * Adaptor: 1/2"Fx3/8"M

1416**Oil Filter Wrench Set (30pcs)**
碗式機油芯扳手組 (30pcs)

Contents:

- * 65-14P, 66/67-14P, 66-6P, 68-14P, 73-14P, 74-15P, 74/76-15P, 75/77-15P, 76-8P, 76-12P, 76-14P, 76-30P, 78-15P, 80-15P, 80/82-15P, 86-16P, 86-18P, 90-15P, 92-10P, 93-15P, 93-36P, 93-45P, 95-15P, 96-18P, 100-15P, 106-15P, 108-15P, 108-18P.
- * Adaptor: 3/8"Fx1/2"M
- * Oil filter wrench capacity: $\phi 65\text{mm}$ - $\phi 120\text{mm}$

**1055****3/8" Dr. Oil Filter Socket Set (5pcs)**
3/8" 機油芯套筒組 (5pcs)

- * Low profile design enables use on cartridge style filters.
- * 3/8" x 24mm x 6PT x 30mm(L). Suitable for BMW
- * 3/8" x 27mm x 6PT x 30mm(L). Suitable for Mercedes A Class, Ford.
- * 3/8" x 32mm x 6PT x 30mm(L). Suitable for GM/OPEL, ASTRA G, CORSA B, ZAFIRA.
- * 3/8" x 36mm x 6PT x 30mm(L). Suitable for BMW, Ford, MONDEO 2.0D DURATORQ, TRANSIT 2.0 & GM/OPEL, OMEGA, VECTRA B, ZAFIRA (98on), Mercedes.
- * 3/8" x 38mm x 6PT x 30mm(L). Suitable for VAUXHALL VECTRA 2.0D.

**TOYOTA Oil Filter Cap Tool**
TOYOTA機油芯扳手

- * Special designed for plastic oil filter cap of TOYOTA.
- * It is easier to use in limited space.
- * Material: aluminum.
- * Size:
1163--1/2" Dr., 64.5mm, 14PT.
1163A--3/8" Dr., 64.5mm, 14PT.

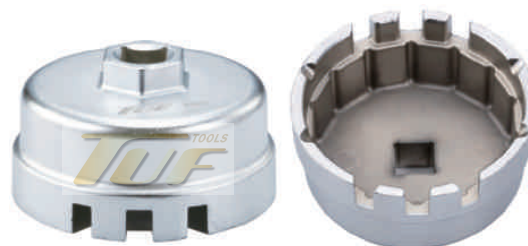
**1164****TOYOTA, LEXUS Oil Filter Socket**
TOYOTA, LEXUS 機油芯扳手

- * Size: 3/8" Dr., 64.5mm, 14PT
- * Material: aluminum.
- * Suitable for TOYOTA 3.5L since 2007, LEXUS: IS250, IS350, GS300, GS350, GS450HE, S350, RX350, LS460, LS600H.





1439

Two Way Oil Filter Wrench
二爪機油芯扳手

- * It designs to remove and install most oil filters.
- * The serrate special design makes forged in place.
- * For filters from 60-80mm.
- * Use with a 1/2" or 21mm wrench.



1417

Oil Filter Wrench
三爪強力型機油芯扳手 (55-95mm)

- * Breakaway torque: min. 150Nm
- * Easy to use; fit for dismounting oil filter of 55-95mm range in diameter. The body could be shrunk to 72mm, fit for almost all small vehicle oil filters.
- * The clamp rods are also able to disassembled and replace with difference length and shape as requirement. Tri-clamp-rods are designed with slip-less feature.
- * Further with magnetic and anti-slip pad at the bottom. It is very easy to adjust with single hand however in a limited space and easy to dismount or mount the oil filter.



1418

Oil Filter Wrench
三爪強力型機油芯扳手 (75-138mm)

- * Breakaway torque: min. 200Nm
- * Easy to use; fit for dismounting oil filter for truck of 70-138mm range in diameter.
- * 1/2" Dr.



1415

Reversible 3 Jaw Oil Filter Wrench
三爪機油芯扳手

- * Works both left & right hand to remove or install filters in hard to reach corners from the top of filter.
- * 3 jaws provide positive grip to the filter.
- * Use with a 3/8" or 1/2" square drive tool.
- * For filters from 2-1/2" to 4-3/4" (60-125mm)



1432

Oil Filter Wrench (27mm)
Ford機油芯扳手

- * Suitable for oil filter on Ford DURATORG TDCI (DW12C) diesel engines.
- * S max, MONDEO, GALAXY, Euro 6 compliant engines from 2010 on wards.
- * Bi Hex x 1/2" Dr.

1410**Swivel Jaw Filter Wrench Pliers****夾式機油芯扳手（可彎式）**

- * Jaws swivel 90° in either direction to access most oil and fuel filters.
- * Works where other oil and fuel filter pliers and wrenches don't.
- * Jaws adjust to 4 positions, (30° increments) to fit most applications.
- * Slip-joint handle offers a big range from 2-1/4" to 4-3/4" (57-120mm).
- * Sure grip teeth prevent slipping.
- * Cushioned handles provide comfort.
- * Length: 320mm.

**Forged Oil Filter Pliers****夾式機油芯扳手**

- * Hardened drop forged Cr-V steel tool removes stubborn filters.
- * Three step slip joint design makes adjustment fast & easy for wide operation range.
- * Toothed profiles prevent the tool slipping.
- 1083**--230mm Oil Filter Pliers (60-90mm)
- 1084**--250mm Oil Filter Pliers (85-115mm)

**1083****1084****1082****Oil Filter Master Pliers****機油芯扳手（固定鉗式）**

- * Multi-purpose pliers, range: 53-118mm.
- * Suitable for installing, removing and tightening objects of any shape.
- * Locks onto the works with terrific grip.

**Chain Wrench****鏈管鉗**

- * **7103**--L: 150mm, range: ϕ 30- ϕ 120mm
- * **1441**--L: 300mm, range: ϕ 30- ϕ 140mm

**7103****1441****Strap Wrench****皮帶式機油芯扳手**

- * **1442**--L: 225mm, range: ϕ 60- ϕ 140mm
- * **1443**--L: 300mm, range: ϕ 60- ϕ 260mm

**1419****12" Strap Wrench****帆布式機油芯扳手**

- * Handle: 12"
- * Strap length: 36"





1117 Oil Screw Socket Tools Set (14pcs)
油底殼螺絲拆裝套筒組 (14pcs)

- * 17mm Hex Dr.
- * Square: 8, 9, 10, 11, 12, 13mm
- * Hex: 8, 9, 10, 12, 14, 17mm and 3/8"
- ⊙ * Spline: M16H
- * 32mm (L)



3009 Mercedes-Benz Transmission and Oil Dipstick
賓士綜合油尺組 (4pcs)

- * Red: 1220mm (L) for transmission type on 722.6
- * Green: 920mm (L) for transmission type on 722.7, 722.8, 716.5
- * Blue: 930mm (L) for engine oil on M112, M113, 646, 647, 648, 271
- * Yellow: 930mm (L) for engine oil on 103, 943, 984, 985, 104, 111, 119, 120, 137.603, 913, 963, 97, 604, 605, 606, 611, 612, 613, 626, 612, 965



3002 Mercedes-Benz Transmission Dipstick
賓士變速箱油尺 (722.6)

- * The tool is designed to measure the oil level of transmission.
- * Full length: 1220mm.
- * Suitable for transmission type 722.6



3003 Mercedes-Benz Transmission Dipstick
賓士變速箱油尺 (722.7)

- * The tool is designed to measure the oil level of transmission.
- * Full length: 920mm.
- * Suitable for transmission type 722.7, 716.5, 722.8



3004 Mercedes-Benz Engine Oil Gauge
賓士機油尺 (直型)

- * Full length: 930mm, balance the top of the oil gauge.
- * Suitable for engine model: 103, 943/984/985, 104, 111, 119, 120, 137, 603, 913/963/97, 604, 605, 606, 611, 612, 613, 626, 965.



3005 Mercedes-Benz Engine Oil Gauge
賓士機油尺 (渦型)

- * Full length: 930mm, the top of the oil gauge can turn back to 90°.
- * Suitable for engine model: 112, 113, 646, 647, 648, 271.



4029**Audi Engine Oil Dipstick**
Audi 機油尺

- * This oil gauge and dipstick is designed for measuring the oil levels on different Audi engines fitted with electronic oil level systems.
- * Suitable for 2009 Audi A4, A5 and A6 with engines 2.0L TFSI, 3.2L FSI and 4.2L FSI and 2.0, 2.7, 3.0 TDI, 1.8, 2.0, 3.0 TFST, 3.2, 4.2 FSI.

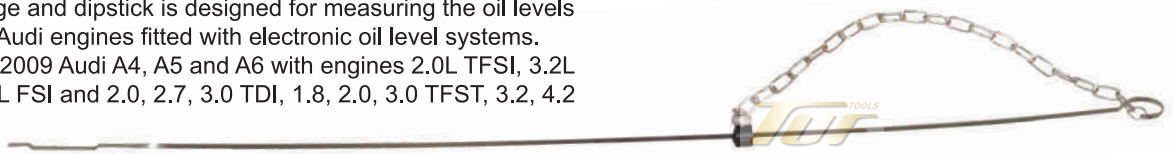
**1430****Flexible Hose Clamp Tool**
可彎式管束夾鉗

- * 640mm heavy duty flexible cable reaches to almost any position.
- * Helps technician to release the hose clamps located in hard-to-reach areas.
- * Ratchet lock function holds the ring in open position for easy removal and installation.
- * Suitable for hose clamp sizes from 18-55mm.
- * PVC dipped handles for close control and comfort.

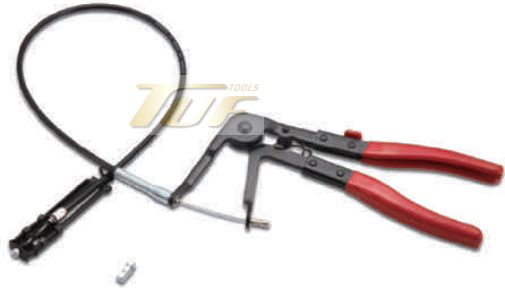
**1433****Hose Clip Tool**
小型喉式管束夾鉗

- * The clamp tool designed to get to confined spaces hose clips
- * Jaw capacity: 0-40mm diameter.
- * Can be used with 3/8" Dr. ratchet flexible extension driver.

**1444****Hose Clamp Pliers**
直型喉式管束夾鉗

- * Ratchet lock mechanism holds jaws open.
- * Works on most flat-band hose clamps.

**1445****Hose Clamp Pliers**
彎型喉式管束夾鉗 (45°)

- * 45° angled jaws and swivel tips for easy access to confined areas.
- * Ratchet lock mechanism holds jaws open.
- * Works on most flat-band hose clamps.

**1142****Hose Removal Pliers**
油管分離鉗

- * Designed for easy removal of 5/32" (4mm) to 1/2" (13mm) vacuum hoses or fuel lines from tubing or fittings.
- * Place the black jaw on the tubing or fitting, the sharp jaw will grip the material. Then squeeze the silver jaw to push the vacuum hoses or fuel lines off the tubing or fitting.





1403

Hose Removal Hook Set (2pcs)

油管分離起子組 (2pc)

- * Remove hoses after the hose clamp is released.
- * Special hook design for easy removal of hoses.
- * Durable big handle provides firm grip.



1446

Sensor Socket Set (14pcs)

感應套筒組 (14pcs)

Contents:

- 1/2" x 17 x 12PT x 78mm (L), 1/2" x 19 x 12PT x 78mm (L), 1/2" x 20 x 6PT x 78mm (L), 1/2" x 27 x 6PT x 78mm (L), 1/2" x 21 x 12PT x 90mm (L), 1/2" x 22 x 12PT x 78mm (L), 1/2" x 22 x 12PT x 110mm (L), 1/2" x 27x 12PT x 78mm (L), 1/2" x 27 x 12PT x 110mm (L), 1/2" x 28 x 12PT x 78mm (L), 1/2" x 30 x 12PT x 78mm (L), 1/2" x 22 x 12PT x 150mm (L), 1/2" x 22 x 6PT offset oxygen sensor socket, 3/8" x 22 x 6PT offset oxygen sensor socket.



1067

Sensor Socket Set (7pcs)

感應套筒組 (7pcs)

* Contents:

- 1/2" Dr. x 29mm x 6PT x 90mm (L), 3/8" Dr. x 7/8" x 6PT x 90mm (L), 3/8" Dr. x 7/8" x 6PT x 80mm (L), 1/2" Dr. x 7/8" x 50mm (L), 3/8" Dr. x 7/8" x 30mm (L), 1/2" Dr. x 27mm x 12PT x 78mm (L), 3/8" Dr. x 1" & 1-1/16" x 74mm (L)

- * For use on Lambda sensors (oxygen sensors) on most modern cars. This tool covers a wide variety of options and fits most heated and non-heated sensors.



1447

Extra Long Oxygen Sensor Socket

特長含氧感應套筒

- * 1/2" Dr. x 22mm x 6PT x 150mm (L)

1009

Oxygen Sensor Socket

含氧感應套筒 (日規)

- * 1/2" Dr. x 7/8" (22mm) x 90mm (L)
- * 7mm slot for oxygen sensor on Japanese cars Ford, GM, CHRYSLER and other cars.

1007**Oxygen Sensor Socket**
含氧感應套筒 (歐規)

- * 3/8" Dr. x 7/8" (22mm) x 30mm (L)
- * 3/8" Dr. x 7/8" flare nut socket or vacuum switch & oxygen sensor service on computer controlled engines.

**1040****Clutch Alignment Set**
離合器對孔校正器 (鐵)

- * Align single disc clutches on most vehicles, light truck & tractors.
- * Properly aligns clutch plate by tapered cone fitting into pilot bushing or bearing.
- * Size: 8 collects ranging from 0.465" to 0.980" (11.8-24.9mm)

**1041****Universal Clutch Aligning Tool**
離合器對孔校正器 (塑鋼)

- * This tool makes the alignment and assembly of clutch easy.
- * Specially designed for those vehicles equipped with late-model front wheel drives without pilot bearing in flywheel.
- * Compact light weight construction allows you to do the jobs on table or work bench.
- * Ideal for vehicles up to 5 tons with single plate clutch.

**1448****Automatic Transmission Clutch Spring Compressor (2 Pins)**
變速箱離合器壓板工具 (2點式)

- * For removing and installing the transmission rear clutch piston snap ring.
- * Special design to assemble & disassemble the clutch snap ring easier.
- * General transmission repair tool.
- * Adjustable for most models of American cars and light trucks.

**1449****Automatic Transmission Clutch Spring Compressor (4 Pins)**
變速箱離合器壓板工具 (4點式)

- * Adjustable legs fit most cars & trucks for replacement of transmission rear clutch piston snap ring.
- * Special design to assemble & disassemble the clutch snap ring easier.
- * Capacity: clutch diameter from 64-175mm





1303



1314



can be rotated for 360°

1313



1039

1303 Trans / Engine Oil Pressure Tester Kit
引擎機油壓力測試器 (雙錶)

Description:

- * Large, rugged, heavy duty 2.5" gauges with protective outer boot designed for professional using.
- * Low pressure gauge reads 0-100psi / 0-7bar and the high pressure gauge reads 0-400psi / 0-28bar.
- * Kit includes a 72" long hose and quick couplers for fast, convenient testing.
- * Also includes 9pcs adaptor for testing most domestic and import vehicles and a detailed instruction manual.

Specifics:

- * Dual 2-1/2" gauge (0-400psi / 0-28bar)
- * Rubber protector
- * 24" (610mm) of oil proof hose with 1/8" NPT
- * 1/4" NPT and 3/8" NPT adaptors

1314 Engine Oil Pressure Tester Kit
引擎機油壓力測試器 (單錶)

Description:

- * Designed to check engine oil pressure in both cars & trucks.
- * Easy-to-read dual scale 2.5" gauge reads 0-300psi / 0-21kg/cm².
- * Also includes 9pcs adaptor for testing most domestic and import vehicles.

Specifics:

- * 2-1/2" gauge
- * Pressure range: 0-300psi / 0-21kg/cm²
- * Rubber protector
- * 6ft (1.8m) of oil proof hose with 1/8" NPT
- * 9pcs adaptor

1313 Vacuum Pump Brake Bleeding Kit
全配備正負壓槍組

- * The kit includes the vacuum pump, and the gauge can be rotated for 360°, complete fittings and accessories for vacuum testing and brake bleeding.
- * The vacuum pump is field repairable.
- * Replace worn o-ring, seals and valves with the vacuum pump repair kit.

1039 Vacuum Pump/Brake Bleeding Kit
全配備真空吸力槍組

- * Universally applicable for the quick and easy check of vacuum systems as well as for the suction of liquids such as fuels, brake fluids etc.
- * Especially required for checking the following: fuel-system, vacuum diaphragm, vacuum sensor, vacuum modulator on automatic transmission, brake booster.

1308**Carburetor Synchronizer Kit (Vacuum)****真空壓力錶組 (四聯錶)**

- * For testing fuel pump carburetor and transmission check auto with 2-4pcs carburetor
- * 4pcs 3-1/2" synchronizer gauge with fixed plate, pressure range: 0-76cmHg
- * 4pcs rubber hose: 8x5x750mm
- * 8pcs extension tube: 3.9x5.2mmx4pcs, 3.9x122mmx4pcs
- * 16pcs cone type connector: 8x40mmx8pcs, 10x53mm(M6x0.75)x4pcs, 10x60mm(M6x1.0)x4pcs

**1301****Deluxe Vacuum / Fuel Pump Tester Kit****真空壓力錶組**

Diagnoses valve leaks, incorrect timing, leaky intake manifold & clogged mufflers. 3-1/2" diameter gauge, includes 3 brass fittings and 4' tube.

**1311****Basic Exhaust Back Pressure Set****排氣背壓錶**

- * Enables technician to test exhaust back pressure through oxygen sensor.
- * Oxygen sensor adaptor includes M12 and M18 thread.
- * The special 2-1/4" gauge has two multi-colored bands-idle 2500RPM, with pressure shown in psi and bar.
- * Hose is 6ft length.

**1450****Mechanic Stethoscope Kit****雙用型音診器**

- * Quick and accurate way to locate noises and trouble spots in engines motors transmissions and drive axles.
- * Spring diaphragm on end of hose amplifies noise listen for and identify faulty valves, bearing rap, worn gears, piston slap. Includes two hose ends: long rod helps pinpoint noises in hard-to-access areas; short adapter helps locate noise in broader area of the vehicle.

**1451****Mechanic Stethoscope****音診器**

- * Locates source of engine noise quickly.
- * Inspect for problem by tracing sound of flowing water, oil, gas or steam.
- * Handle is shockproof.





1159 Manual / Pneumatic Fluid Extractor
手動/氣動抽油機 (雙用)

- * Capacity: 10.5L
- * Pneumatic & manual operation fluid extractor of non-sparkle.
- * Three air outlets with check valve design for quick & easy to exhaust the air from the extractor.
- * Easy to operate suitable for engine oil, gear oil, brake fluid, water.
- * Provide with new design decompression valve or easy to release the negative pressure.

Spare parts available for order separately (選購配件)



1159-1
Bleeding tube with shut off valve.



1159-2
Refill Pot



CJ-169 Oil VAC
手動式抽油機

- * Capacity: 6.5L
- * The unit is ideally suitable for extracting or changing engine oils or lubricants in motor vehicles, motor bikes, marine engines, stationary engines, as well as non lubricants such as water from fish tanks etc.



1157 Pneumatic Brake Fluid Changer (2L)
氣動式剎車油吸取機

- * Versatile-handles most standard and ABS brake systems.
- * Clean-collects old brake fluid without spillage.
- * Quiet-integrated silencer for a quieter working environment.
- * Capacity: 2L



2012



2012A

2012 Hand Operated Oil & Liquid Dispenser
手動加油機 (附接頭)

* Suitable for transmission filling system

2012A Hand Operated Oil & Liquid Dispenser
手動加油機 (13pcs 附接頭)

* Suitable for transmission filling system



PARTS NO.	PARTS	SUITABLE	2012	2012A
101		Ford 1/8"-27(NPT)	✓	✓
102		Universal BMW, HONDA, NISSAN, etc.	✓	✓
103		VW / Audi, SKODA	✓	✓
104		VW / Audi, PORSCHE	✓	✓
105		VW / Audi, MINI COOPER M10x1.0	✓	✓
106		VW / Audi DSG M24x1.5	✓	✓
107		VW / Audi CVT M22x1.5	✓	✓
108		Mercedes M12x1.5	✓	✓
109		NISSAN, INFINITY M8x1.0		✓
110		VW / Audi, SKODA M30x1.5		✓
111		Universal Flexible 300mm		✓
112		VOLVO 5/16"-24(UNF)		✓
113		TOYOTA, LEXUS M18x1.5		✓